

**TRAVEL TRAILER  
&  
FIFTH WHEEL**

**OWNER'S  
MANUAL**

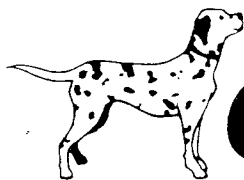

**Coachmen**  
INDUSTRIES, INC.



## TABLE OF CONTENTS

<u>Chapter</u>	<u>Page</u>
COACHMEN WARRANTY .....	3
YOUR TOWING VEHICLE .....	5
YOUR COACHMEN TRAVEL TRAILER .....	6
PREPARATION AND USAGE .....	8
WATER SYSTEM .....	11
DRAINAGE SYSTEM .....	13
ELECTRICAL SYSTEM .....	14
LPG SYSTEM .....	17
APPLIANCES .....	18
THE 5TH WHEEL TRAILER .....	23
OPTIONAL EQUIPMENT .....	24
CONVENIENCE ITEMS .....	24
CARING FOR YOUR COACH .....	26
TRAILER STORAGE AND WINTERIZING .....	26
MAINTENANCE .....	27
WEIGHTS OF RV SUPPLIES & EQUIPMENT .....	28
INDEX .....	31

## FOREWORD

*Welcome to the Coachmen family. You will experience many hours of fun, adventure, relaxation and enjoyment with your new Coachmen travel trailer.*

*Many years of trailering experience from owners, dealers and our personal experience have been incorporated into the design and engineering of your unit. Your travel trailer has been built by experienced craftsmen to the rigid specifications of Coachmen Industries. Only the finest components and materials have been used.*

*You will benefit from the comfort, convenience, reliability and safety built into every Coachmen recreational vehicle. This owner's manual will assist you in obtaining the maximum enjoyment from your unit. It explains the operation and use of your Coachmen.*

## CHAPTER 1

### COACHMEN WARRANTY

A warranty registration form has been made out by your Coachmen Dealer. You should have in your possession the third copy of this three-part form for warranty verification until your wallet-size, plastic owner's card is mailed to you by Coachmen Industries.

This card will provide proof of ownership along with the necessary data for warranty adjustment. Be sure to have this card in your possession (or the temporary warranty registration form) should warranty adjustment be necessary.

All warranty repairs and adjustments should be done at an authorized Coachmen Dealer. You should return your unit to your selling dealer for warranty service unless you are out of town on a trip.

Requests for repair parts and all product information should be directed through an authorized Coachmen Dealer.

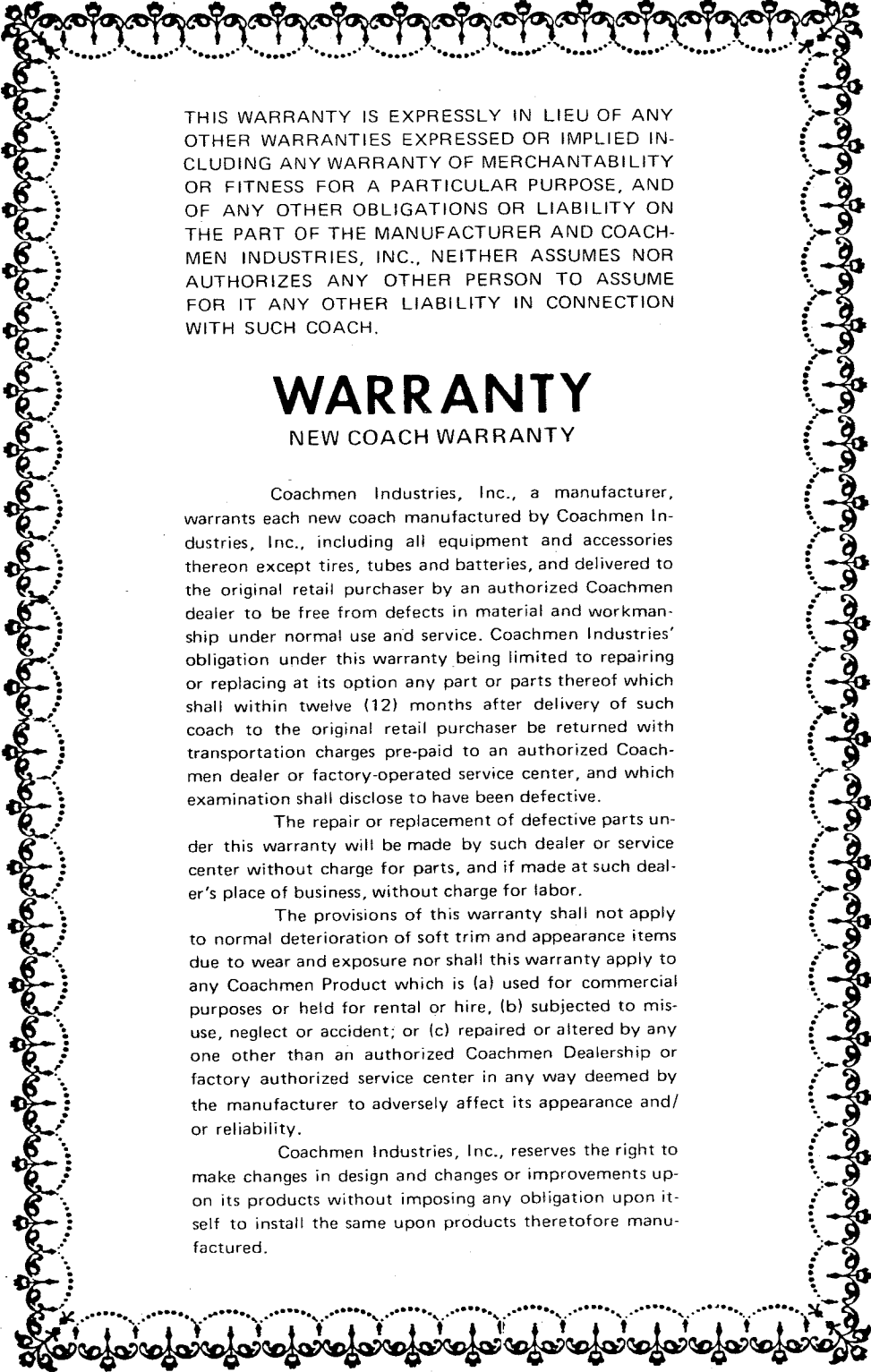

THIS WARRANTY IS EXPRESSLY IN LIEU OF ANY OTHER WARRANTIES EXPRESSED OR IMPLIED INCLUDING ANY WARRANTY OF MERCHANTABILITY OR FITNESS FOR A PARTICULAR PURPOSE, AND OF ANY OTHER OBLIGATIONS OR LIABILITY ON THE PART OF THE MANUFACTURER AND COACHMEN INDUSTRIES, INC., NEITHER ASSUMES NOR AUTHORIZES ANY OTHER PERSON TO ASSUME FOR IT ANY OTHER LIABILITY IN CONNECTION WITH SUCH COACH.

## WARRANTY

### NEW COACH WARRANTY

Coachmen Industries, Inc., a manufacturer, warrants each new coach manufactured by Coachmen Industries, Inc., including all equipment and accessories thereon except tires, tubes and batteries, and delivered to the original retail purchaser by an authorized Coachmen dealer to be free from defects in material and workmanship under normal use and service. Coachmen Industries' obligation under this warranty being limited to repairing or replacing at its option any part or parts thereof which shall within twelve (12) months after delivery of such coach to the original retail purchaser be returned with transportation charges pre-paid to an authorized Coachmen dealer or factory-operated service center, and which examination shall disclose to have been defective.

The repair or replacement of defective parts under this warranty will be made by such dealer or service center without charge for parts, and if made at such dealer's place of business, without charge for labor.

The provisions of this warranty shall not apply to normal deterioration of soft trim and appearance items due to wear and exposure nor shall this warranty apply to any Coachmen Product which is (a) used for commercial purposes or held for rental or hire, (b) subjected to misuse, neglect or accident; or (c) repaired or altered by any one other than an authorized Coachmen Dealership or factory authorized service center in any way deemed by the manufacturer to adversely affect its appearance and/or reliability.

Coachmen Industries, Inc., reserves the right to make changes in design and changes or improvements upon its products without imposing any obligation upon it- self to install the same upon products theretofore manufactured.

## APPLIANCE AND COMPONENT IDENTIFICATION SHEET

EQUIPMENT	MANUFACTURER	MODEL NUMBER	SERIAL NUMBER
Travel Trailer	COACHMEN		
Refrigerator			
Range/Oven			
Heater/Furnace			
Water Heater			
Toilet			
Water Pump			
Tires			
Spare Tire (Opt.)			
Converter (Opt. on Cadet Series)			
Door Key			
Air Conditioner (Opt.)			

Should you have any problems, be sure that you identify the trailer and/or equipment model and serial numbers when you contact the dealer for assistance.

NOTE: For your convenience we suggest you complete this page for easy reference.

## CHAPTER 2

### YOUR TOWING VEHICLE

Today, with more powerful cars and super highways, almost any medium-sized vehicle has enough power to tow a travel trailer under level, dry conditions. Heavy-duty suspensions, heavy-duty radiators with built-in transmission coolers, larger engines, larger alternators, higher capacity batteries and larger tires, along with lower rear axle gear ratios, are available to give you greater vehicle towing performance.

<u>Trailer GVWR</u>	<u>Horsepower</u>	<u>Recommended Equipment</u>
2,000 to 3,000 lbs.	Over 150	Load-equalizer hitch and heavy-duty shock absorbers
3,000 to 5,000 lbs.	Over 200	Load-equalizer hitch mandatory. Heavy-duty springs, shocks, tires, cooling and electrical system.
Over 5,000 lbs.	Over 275	Same as above.

#### Special Towing Equipment for Your Towing Vehicle

##### LOAD EQUALIZING HITCH:

A Load Equalizing hitch is recommended. This hitch distributes the hitch weight of the travel trailer equally to all four wheels of the towing vehicle and partially to the trailer wheels. This hitch also helps eliminate sag on the rear of the towing vehicle, thereby allowing a level hook-up.

##### HEAVY-DUTY SHOCK ABSORBERS:

Heavy-duty shock absorbers provide better performance and are recommended.

##### HEAVY-DUTY SPRINGS:

Heavy-duty springs are recommended and aid your towing vehicle in carrying the additional load of the travel trailer and equipment.

##### SIDE VIEW MIRRORS:

Side view mirrors that mount on each side of the towing vehicle are a **MUST**. They are required by law in most states. The universal mounting type that mounts on fender or door and can be removed easily when not in use, is recommended.

##### TRANSMISSION COOLERS:

A transmission cooler is beneficial for extended towing in hot climate or on hilly terrain. Those who use them claim fewer overheating problems and longer transmission life.

##### TIRES:

Proper tires are extremely important to your

When buying a new automobile, order the trailer towing package recommended by the vehicle manufacturer. Give the auto dealer the information on hitch weight and gross weight of your travel trailer so he can specify the correct towing package.

Cars with less than 150 horsepower will tow a trailer satisfactorily if the weight does not exceed two-thirds of the towing vehicle's weight. For example, a vehicle weighing 3,200 pounds towing a trailer from 2,000 to 2,400 pounds should be satisfactory.

The following chart may be used for reference:

safety. Be sure your tires have adequate load carrying capacity and are inflated to the correct tire pressure.

##### HEAVY-DUTY FLASHER:

A heavy-duty flasher is normally needed to properly operate the extra turn signal lamps on your trailer.

##### SWAY CONTROL SYSTEM:

A sway control system is helpful. Either the cam or friction type system is available.

##### BRAKE CONTROLLER:

The brake controller is installed on your towing vehicle to operate the electric brakes on your trailer. The controller, mounted on the steering column or under the dash, can be operated separately or automatically with your foot brake. The controller synchronizes the brakes on your trailer with the brakes on your towing vehicle.

##### ELECTRICAL CONNECTOR:

The electrical connector should be installed on the rear of your towing vehicle so that your trailer brakes and lights will operate simultaneously with those on your towing vehicle.

##### HITCH WEIGHT:

To check for proper height:

- (1) Park towing vehicle and trailer on level ground.
- (2) Level trailer with lift jack and measure distance from ground to inside top of ball socket—about 19 to 19½ inches for 700 x 15 tires and approximately 18 inches for units equipped with 855 x 15 tires.

This should be one-half to one inch shorter than the

measurement of the distance between ground and top of ball mounted on the towing vehicle. The additional one-half to one inch is to compensate the towing vehicle settling due to the added weight of your travel trailer.

The Load Equalizing Hitch, Brake Controller and Electrical Connector should be installed by your Coachmen Dealer or an installer recommended by him. These are critical components and proper installation is important to safety and performance.

## CHAPTER 3

### YOUR COACHMEN TRAVEL TRAILER

#### ELECTRIC BRAKES

The Kelsey-Hayes two-shoe adjustable brakes on your Coachmen travel trailer are the finest electric brakes available on the market. They are operated via the 12-volt current from your towing vehicle and are hooked up so that you have an integral system with your car brakes. Below is a diagram of the brake system and its components:

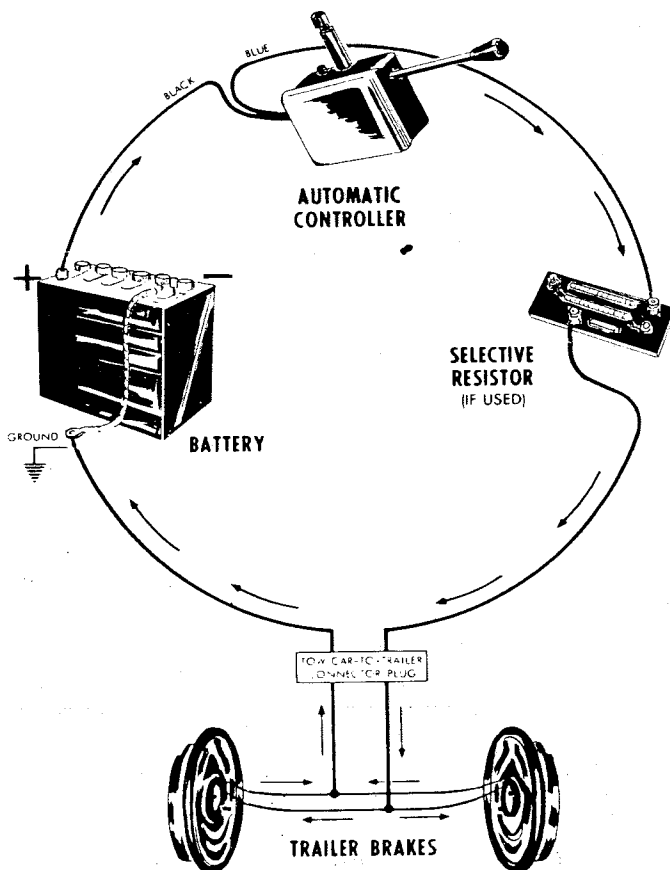

To better understand the operation of the brake system, study the following steps:

1. The required electrical energy originates at the battery of the towing vehicle.

2. From the battery the circuit is connected to the controller. This controller adjusts the flow of current to the brakes automatically when you apply your towing vehicle's brakes or when you touch the brake controller lever inside your towing vehicle.

3. Your brake system may require a resistor to limit the flow of current if your towing vehicle's battery output is higher than needed to operate your electric brakes. Be sure to check with your Coachmen dealer regarding the necessity for this resistor for your towing vehicle.

4. Once the current passes through the controller, it flows through the towing vehicle to the trailer connector plug. NOTE: It is important to keep this connection clean, tight and well-protected from the weather to insure proper current flow.

5. From the connector the current flows to the trailer brakes. Kelsey-Hayes electric brakes are similar in design and construction to automotive brakes. They provide efficient, smooth and instantaneous responses to variations in electrical current flow passing through the controller.

6. The rest of the circuit is called the ground. For best results, it is important that the ground flows back through the connector. From the connector plug the ground wire should be attached to a good, clean, secure ground point on the towing vehicle chassis or engine.

Most states require a break-away switch. This device, when properly wired to a separate power source, will apply your trailer brakes in the event your towing vehicle and trailer should ever become separated. Although this rarely happens, should it happen to you, the break-away switch will automatically apply your trailer brakes.

#### Running Gear

Most Coachmen trailers are equipped with tandem wide-track axles and have electric brakes on all four wheels. (One axle on some Cadet models.) The following preventative maintenance steps should be observed for best results:

1. Check your wheel lugs for tightness every 50 miles for the first 200 miles and before every trip thereafter.

2. Recheck wheel lugs more often if your trip is over rough terrain.

3. Check and repack wheel bearings once a year or every 5,000 miles, whichever comes first.

4. If you store your trailer during the winter months, it is a good idea to repack bearings in the Spring to remove any moisture that may have collected in the bearings.

5. Keep bolts free from rust.

6. Make sure hub caps are secure.



7. The springs on your unit have fiber bushings and never need lubrication.

### Tires

Your Coachmen trailer is equipped with good quality name-brand tires that have been selected to give you the best performance and tires that can be adjusted for warranty in any medium-sized city across the country.

Proper tire inflation is very important and care must be taken not to overlook this simple periodic check. For best results, inflate your tires before each trip as follows:

650 x 13 (4 ply) = 40 pounds  
 700 x 15 (6 ply) = 45 pounds  
 855 x 15 (6 ply) = 45 pounds

Under-inflated tires may cause a unit to sway, will shorten the life of the tread and decrease its load limit. Over-inflation can create a bouncing, rough ride and it increases the hazard of blowouts.

To change a tire, first lower the front dolly jack on the "A" frame of your trailer. Then block the tire on the opposite side of the unit, raise up the wheel with the flat tire using a hydraulic jack placed under the main frame just behind the tandem axles. After the tire clears the ground, remove bolts and change tire. Replace bolts and tighten. Remove hydraulic jack and raise dolly jack.

Tires are warranted by the tire manufacturer. If you should require an adjustment on a faulty or defective tire, consult the tire manufacturer's nearest dealer (check the classified pages of the telephone directory for the name and address of the nearest tire dealer).

It is a good idea to carry a spare tire at all times. Carriers mounted on the rear bumper provide safe, convenient storage and free up inside space for other items. Ask your Coachmen dealer for a Kenco spare tire kit.

### Equipping Your Travel Trailer

The following list of auxiliary equipment should be carried in your trailer. Your Coachmen Dealer can help you with your needs. The following items are **RECOMMENDED**:

#### SAFETY CHAIN:

Heavy-duty—attached to your trailer and your towing vehicle's frame as required by law in many states. Safety chains are standard on your Coachmen travel trailer.

#### BREAK-AWAY SWITCH:

Should be mounted on trailer to actuate the trailer brakes in case of accident. If the trailer were to separate from the car, the brakes would lock. The pull pin of the safety switch must be attached to the towing vehicle by a

wire in such a way as not to be accidentally pulled out during normal towing. This safety switch is required by law in many states. The break-away switch is furnished by Coachmen for installation by your dealer.

#### TOOL BOX:

An assortment of hand tools such as screwdriver, pliers, crescent wrench, etc., will often come in handy on your trip.

#### STABILIZING JACKS (FOUR):

Two for the front and two for the rear. These should be placed under the main steel frame when stabilizing and leveling the trailer.

#### WHEEL BLOCKS:

Place them against the tires to prevent the trailer from moving while parked. They should be as wide as the tires and slanted on one side.

#### LEVELING RAMP:

A leveling ramp is helpful when leveling your travel trailer from one side to the other side when your parking space is not level. This ramp can be made from a three foot length of 2 x 6-inch board and tapered from one end to the other.

#### WATER HOSE:

Fifty feet of 5/8-inch hose and a Y-type water fitting, should you need to share a single water faucet at the camp site.

#### LEVEL:

For use in leveling your trailer. The bubble type mounted on the trailer is convenient.

#### DRAIN HOSE:

For use in emptying your holding tank. This hose should be stored in the rear bumper of your travel trailer. Hose fittings are provided with your self-contained Coachmen unit.

### THE FOLLOWING OPTIONAL ITEMS

#### ARE ALSO RECOMMENDED:

Spare tire and wheel.

Hydraulic Jack—two-ton to three-ton, depending on size of trailer.

Cross Type Lug Wrench—for trailer wheels.

Stabilizing Jack Blocks—will keep your stabilizing jacks from sinking into soft or muddy ground (6" x 6" x 1" blocks of wood are good).

Tire Gauge—to insure proper and equal inflation.

Emergency Road Flares—two should be carried at all times. Four 4" x 4" emergency reflectors are also useful.

Flashlight—two-cell in good working condition, preferably one with red lens cover.

Electric Extension Cord—25-foot with a 30-amp

8.

capacity.

First Aid Kit.

Spare Fuses—of the type used in your trailer and automobile.

Plastic Containers—for water.

Large Funnel.

Plastic Pails—for use if drainage facilities at camp site are not available.

Short Handled Shovel.

Fire Extinguisher—general purpose. This should be checked periodically.

## CHAPTER 4

### PREPARATION AND USAGE

#### Loading Your Travel Trailer

Your Coachmen travel trailer has been designed to provide maximum convenience and storage space. The supplies, equipment and personal belongings that you need in a home-away-from-home can be carried without difficulty, providing the weight is distributed properly.

Proper weight distribution within your trailer is an important consideration to insure maximum efficiency of the trailer brakes, hitch and load equalizer. It also eases the load of your towing vehicle. (**Care should be exercised not to overload your unit.**) The total load carrying capacity of your unit GVWR (gross vehicle weight rating) is shown on the federal identification tag located on the left side of the trailer near the front of the unit. When fully loaded with LP gas, water and your provisions, the weight of the unit must not exceed the listed GVWR.

The center of gravity and hitch weight of your towing vehicle have been calculated to provide safe and easy towing. You can maintain this balance by following these basic rules:

1. Keep your trailer as light as possible.
2. Distribute the weight as evenly as possible.
3. Store heavy items over the axles and near the floor.

Heavy items such as canned goods, cooking utensils, books, etc., should be placed in the lower storage areas near, or slightly forward of, the wheels. Storing heavy items in low storage areas will help maintain a low center of gravity. Light and bulky items such as blankets, clothing and light-weight but bulky packaged foods should be placed in overhead storage areas.

A hitch weight that is too light can cause the front end to float and the trailer to weave at higher speeds. This is the result of excessive loading behind the axle. Excessive forward loading places an unnecessary burden on your towing vehicle and displaces weight forward of the axle, which naturally lowers braking efficiency.

Fragile items should be stored well forward of the axles as the front of the trailer is stabilized by the hitch. Fragile items should be wrapped with a protective cover. All liquids should be tightly sealed. Bulky items that cannot be stored in cabinets or closets should be placed on the floor and blocked or tied down to prevent shifting.

#### Hook Up

Hitching up your Coachmen travel trailer may seem difficult the first time, but will become easy after a little practice. Until you have learned from personal experience, the following tips will help you:

1. Turn the jack handle and raise the trailer hitch coupler high enough for the towing vehicle ball to slide under the trailer hitch coupler. Raise the locking lever.
2. Line the towing vehicle up with the trailer and back straight to the hitch coupler. Someone assisting you on the first few attempts is helpful, but with experience you will learn to align the towing vehicle with the jack post and hook up by yourself.
3. When you have aligned the hitch ball under the trailer hitch, turn the jack handle to lower the coupler to engage the hitch ball. Be certain the coupler has fully engaged the hitch ball.
4. Place the locking lever in the "down" (locked) position and insert lock pin in the locking lever handle.
5. Jack up the trailer to a point just above level (see diagram) and install equalizer bars. After you have hitched up a few times, you will know how many links you need to drop in order to have your rig level. A piece of tape wrapped around the proper link is an easy way to insure proper hook up each time. You should always check to be sure your rig is level since your load may change, thus, requiring an adjustment in link location.
6. Attach your sway control system.
7. Attach the break-away cable to your towing vehicle's frame.
8. Attach safety chains to the frame of your towing vehicle.
9. Turn jack handle to retract the hitch jack to its maximum distance from the ground and always remove the dolly wheel. Stow in a safe place.
10. Plug in the 12-volt electrical connector to your towing vehicle. Be sure that the two connectors are locked together by the connector cover. Check running lights, direction lights and brake lights to be sure they operate properly.
11. Start towing your travel trailer slowly and check the trailer brakes to make sure they operate smoothly before driving at normal safe highway speeds.

#### Towing

If you have not had previous experience in towing trailers, you can benefit greatly from a few hours practice in an empty supermarket parking lot or other

## HITCH INSTALLATION



HITCH BALL TOO LOW



HITCH BALL TOO HIGH



CORRECT HOOKUP

open area. You may practice turning right and left corners, as well as backing and parking. As you drive the rig for the first time, you experience an exciting feeling, along with the thought that trailer towing makes a few new demands on the driver. The following conditions need to be remembered in trailer towing:

1. With the trailer attached it is completely natural that you cannot accelerate as fast as normal. Allow more distance when you are pulling out into the traffic. In the same sense, you will need more room for stopping. Practice braking sooner and smoothly.

2. When turning corners, your trailer wheels will not follow the path of the towing vehicle's wheels; therefore, wider turns are necessary. To negotiate corners, keep as far to the **left** of your lane as possible through the entire turn. Make sure you have sufficient room for this maneuver from oncoming traffic. Use your turn signals properly to alert other drivers of your intentions.

3. With the extra weight and length now under your control, stay back a little further from cars in front of you and anticipate traffic movements ahead of you. Also, you will need more time to react when pulling your car/trailer rig. Practice being a more defensive driver.

4. It is a long way back to the trailer bumper—at least twice as long as normal, so when passing do not return into the right-hand lane too fast or your trailer might come in contact with the vehicle you are passing. Do not forget the added length of the trailer. Give

yourself plenty of distance to pass or do not pass at all.

5. Frequently check your rear view mirrors to observe traffic conditions and your travel trailer. Change lanes carefully, always signalling in ample time.

6. Prepare for buses and/or large trucks that are meeting or passing your rig. Large units such as these displace air in such volumes that it often causes a slight sway—this is normal. To counteract this reaction, be prepared to accelerate slightly and adjust your steering wheel very slightly when you feel the force.

7. On a two-lane highway it is common courtesy to pull off the road at a safe place and allow traffic lined up behind you to pass.

8. When climbing steep, long grades with your travel trailer, engine overheating may become a problem. Shifting down to a lower gear (or with an automatic transmission, to a lower range before it seems necessary) will greatly aid engine cooling. The increased engine speed will help circulate the water in your cooling system faster and will also allow the towing vehicle's transmission to work with less effort. If you anticipate overheating problems, you can help your towing vehicle by turning off your towing vehicle's air conditioning system. If your towing vehicle should overheat, turn on your heater to high heat to help dissipate the heat until you can safely pull off the shoulder or at a rest area. Keep your engine running a little faster than at idle until the engine cools down. If your towing vehicle has a light to indicate "hot," run your engine for a few minutes

after the "hot" light goes out before proceeding on with your trip.

9. When descending a steep downgrade, shift to a lower gear, or with an automatic transmission to a lower range (thus allowing the engine compression to brake your descent and slow down your rig). Avoid using your brakes except if necessary. Smoothly apply your brakes when approaching and entering sharp turns.

10. When stopping on a hill, you should use blocks at the trailer wheels and not depend on the "park" position of the transmission. Do not use the break-away switch as a parking brake.

11. When traveling through mud or sand, always try to maintain a steady speed. If you should get bogged down, unhitch from the trailer and back up to the coupler on an extreme angle or jackknife position and re hitch. Slowly and smoothly accelerate. This should free the travel trailer wheels on one side and allow the trailer to free one wheel at a time. If need be, repeat from the other side.

12. You should always travel at reduced speeds on wet or icy highways so that you have better control of your rig and more time to anticipate emergency situations.

13. When backing into a parking space, select a site on the left of your trailer if possible. It is easier to see the rear of your trailer and the parking site when you are backing to your left.

14. Always check your trailer at rest and refueling stops. Here are some suggestions for your check list:

- a) Make sure your hitch coupler is locked, safety chains attached, break-away intact and electrical coupler locked. Make sure everything is secure.
- b) Walk around trailer to observe any low pressure in tires. Do not remove air if pressure is high. Only check tire pressure when tires are cool.
- c) Check your running, directional and stop lights and replace any burned out bulbs immediately.

**NOTE: ALWAYS remember that winds . . . slick, rough or winding roads . . . speed or an overloaded or improperly loaded trailer could diminish the control you have over your towing vehicle and trailer.**

### Backing and Parking

When towing your travel trailer, situations will arise that will require you to back your rig. Do not despair; backing is much easier than you think. The following procedure will assist you:

1. Line up the trailer and the towing vehicle. Grasp the bottom of the steering wheel of your towing vehicle; turn the wheel slowly in the direction you want the travel trailer to move, and slowly back up your rig.
2. As your travel trailer moves toward the desired

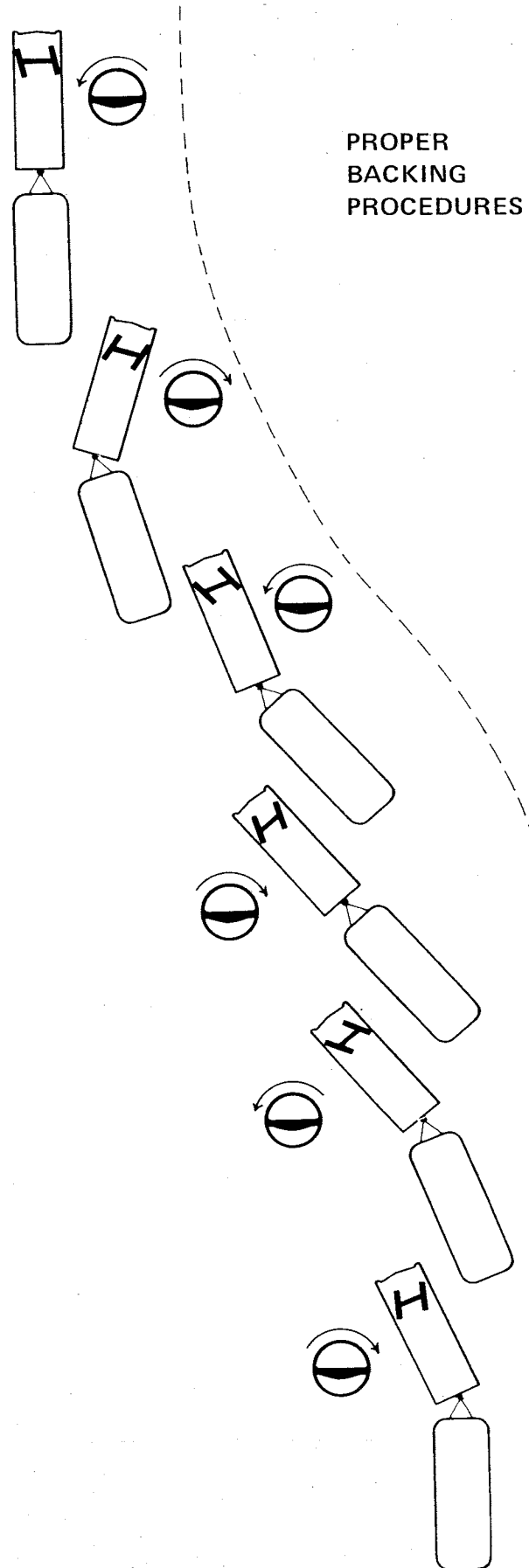

direction, turn your steering wheel slowly in the opposite direction to guide the travel trailer into the parking site.

3. If the travel trailer is not going into the desired spot, pull forward and repeat the procedure. After you have practiced backing a few times, you will notice the ease with which your travel trailer can be parked.

### Overnight Parking

There are thousands of good private and public trailer parks where electricity, water and sewage facilities are available. Directories are available which describe these parks and list available services.

If your towing vehicle is not needed for transportation, it is not necessary to unhitch each night. We do suggest, however, that you attach the dolly wheel and lower the front jack to take the weight off the rear of your car and to stabilize the trailer. Also, disconnect the plug to the vehicle.

For proper operation of the gas refrigerator and to facilitate cooking and sleeping, your trailer should be relatively level.

Lower the tongue of the trailer until it is level. Use two stabilizing jacks under the main frame directly behind the running gear. Additional stability can be obtained by using two additional stabilizing jacks under the front of the trailer. You may find it necessary to remove the hitch spring bars to level your trailer, depending on the terrain where you are parked.

If you wish you can hook up to electricity, water and sewer (if available). Turn your gas on at the container. To use your sink, remove the cap from the sewer drain and place a pail under it or hook up to the sewer service. Always keep the slide valve closed to retain toilet waste in the holding tank until you reach a sanitary dumping station. Remember, a good camper never empties the holding tank on the ground.

### Extended Stay

Staying at a park or your very own retreat for three or four days or longer is similar to an overnight stay, only you will want your Coachmen trailer to be as steady and level as possible for that permanent feeling. You will want to use your towing vehicle to take side trips or trips to the store.

1. Check the side-to-side level of your trailer with a level. If a correction is needed, it can be accomplished by pulling the low side of the trailer up on one of your leveling ramps.

2. Place wheel blocks at wheels on each side of the trailer.

3. Remove safety chains, detach break-away switch cable and disconnect electrical coupler from towing vehicle.

4. Attach dolly wheel and turn the trailer jack

handle to raise the hitch until pressure is released from the load equalizer bars. Remove the sway control and equalizer bars and store. Care should be taken not to get dirt on the lubricated ends of the equalizer bars.

5. Turn the jack handle to lower the trailer hitch coupler and release the coupler hitch lock.

6. Turn the jack handle to raise trailer coupler off the towing vehicle hitch ball. Then pull towing vehicle forward.

7. Level trailer by turning jack handle.

8. Place two stabilizing jacks under the steel frame at the rear of the trailer. Adjust each jack so that it touches the bottom of the frame.

9. Slide both stabilizing jacks out and extend the jack screw up one inch on each.

10. Turn jack handle to lower the hitch and place the two rear stabilizing jacks in place.

11. Turn trailer hitch jack to raise trailer hitch unit level.

12. Use two stabilizing jacks to stabilize the front of the trailer by placing them under the steel frame at the front of the unit.

After leveling your trailer, you may connect water, electrical and sewer service that is available. Turn on the gas and light your pilots. Always keep a roof vent or side window slightly open for proper ventilation when gas is turned on.

## CHAPTER 5

### WATER SYSTEM

#### Deluxe

The water system gives you hot and cold running water, the same convenience you have in your home or apartment.

The water system consists of fill connection, water storage tank, water heater, sink, lavatory, shower or tub and toilet.

A 40-gallon (30-gallon in some units) water tank with a demand pump supplies water throughout the system at the turn of a faucet or by flushing the toilet. The pump is 12-volt and runs off the battery. The water tank is simply filled by gravity feeding. To fill the water storage system, first check to be sure the drain valves are closed. Then turn on the water pump switch.

Fill through the water receptor on exterior of the coach until full. Open hot water faucets to be sure there is full flow of water. This will assure that the hot water heater has been filled. Turn off the water supply. Close the fill receptor. Whenever it is possible to hook up to a city water system, connect water hose to the city water connection. Open the kitchen cold water faucet to assure water flow.

### Coachmen Cadet Standard Water System and Options

The Cadet model travel trailer water system consists of filler spout, plastic water storage tank and a combination hand pump/faucet to supply water to your kitchen sink.

To operate, open the filler spout on the side of the trailer and fill the storage tank with water. When you require water at the sink, operate the pump handle up and down. If you add an optional electric water demand pump and a single faucet to your system, the electric pump will automatically switch on and off, delivering water each time the faucet is turned on and off. (An optional marine toilet can be added to this system.)

### Instructions for Draining the Water System

Water systems should always be drained during periods of non-use to assure fresh water on your next trip. To drain, open the drain valves on the bottom of the coach (including the drain valve on hot water heater). Open all water faucets; then turn on water pump to drain water lines. Shut off water pump once the system is empty.

### Instructions for Sanitizing Potable Water Systems

To assure complete sanitation of your potable water system, it is recommended that the following procedures be followed. On a new system, or one that has not been used for some time, or one that may have become contaminated:

1. Prepare a chlorine solution using one gallon of water and add  $\frac{1}{4}$  cup of Chlorox or Purex household bleach (5% sodium hypochlorite solution). Pour one gallon of this solution into tank for each 15 gallons of tank capacity.
2. Complete filling of tank with fresh water. Be

sure to open each faucet and drain cock until all air has been released from the water pipes and the entire water system is filled.

3. Allow to stand for three hours.
4. Drain system. Flush with fresh water.
5. Drain tank and again flush with fresh water.

### Water Management

Remember, this is your water system—check the water **before** filling your tank. Here are some hints:

1. Don't use a dirty water hose. Particles have a way of ending up at the faucet.
2. Some plastic and rubber hoses often leave an odd taste in the water. Ask your dealer for an approved water hose.
3. Always taste the water before filling your tank. If not to your liking, drive on to another source.
4. If you don't want to fill your water tank where the water supply has objectionable minerals, sulphur or salt, and you need water for dishwashing, etc., fill two 5-gallon plastic folding jugs and keep your water system clean. Bottled water sold in most supermarkets can also be used for drinking and cooking.
5. If your travels take you to areas where the water purity is questionable, consider purchasing a water purifier for installation in your unit. These remove bad tastes and kill harmful bacteria. Chlorine (ordinary household bleach) and chlorine tablets can be used to sanitize water.
6. Another important item to remember is the maximum recommended pressure of 75 Psi for the water system. It has been tested and proven fail proof at 100 Psi. A pressure regulator is recommended to avoid excessive pressure. Ask your Coachmen dealer.

### DEMAND PUMP WATER SYSTEM TROUBLE SHOOTING

<u>PROBLEM</u>	<u>POSSIBLE CAUSE</u>	<u>SOLUTION</u>
Pump does not run.	Battery discharged Blown fuse Disconnected wire Switch off Pump head may be jammed by foreign object  Water in pump may be frozen	Charge battery Replace fuse Check and repair Turn on switch Remove hoses from pump & see that blades are free to turn Use electric light bulb placed near pump to provide heat for thawing
Pump runs but water does not appear.	No water in tank Kink in pump hose Air leaking in at inlet fitting Clogged line from tank	Fill tank Straighten hose Tighten clamps Remove line & check for object in line & remove.
Pump runs but water sputters.	Air in lines  Air in lines from tank	Run pump to clear air from lines  Tighten clamps

DEMAND PUMP WATER SYSTEM TROUBLE SHOOTING (Cont'd)

<u>PROBLEM</u>	<u>POSSIBLE CAUSE</u>	<u>SOLUTION</u>
Pump cycles On & Off	Leak in system Open or leaking faucet	Check lines for leaks Close faucet or repair leaking faucet
	Air in hot water tank	Run hot water to remove air
Pump does not shut off	Stuck switch on pump	Tap lightly with hammer or screwdriver head.
	Low battery	Charge battery

## CHAPTER 6

### DRAINAGE SYSTEM

The system used to drain the bathroom and kitchen wastes from your trailer is designed for service in two types of usage:

1. Self-contained service while on the road or when parked without being connected to a sewer line.
2. Stationary use connected to a sewer for overnight or lengthy stays.

Except for the holding tank, the drainage system is very much like the system at home.

The kitchen sink, bath sink and shower/tub all drain to a large 3-inch diameter quick disconnect cap which must be removed for proper drainage. The sewer hose is connected to this drain and to an in-park sewer system. If not connected to a park sewage system, a plastic pail should be placed under the drain opening to catch dish and shower water to avoid mud puddles and to prevent detergents from killing foliage.

The toilet drains directly into a holding tank which has the capacity for retaining your sewage for several days under normal usage. The dump valve is located near the sewer line drain pipe. When the slide valve is pushed in, the valve is closed. Be sure the sewer hose is connected before opening valve. To open this valve, first remove the cap at the end of the drain line by rotating it counter-clockwise (or left to right), then pull the handle out quickly.

**CAUTION:** If the drain cap is left on the end of the drain line, water from the sink and bath have no way to get out of the trailer and consequently will back up into the lowest drain (which is the shower).

**NOTE:** The Royal Coachmen sewer line drainage system simply uses two wire clips which secure the valve handle in place. These must be removed to pull the handle.

### Holding Tank

Your sewage holding tank is designed and constructed to be non-corrosive and leak-proof and to afford you maintenance-free operation. The capacity of the holding tank varies with the trailer model. Ask your dealer for the standard size holding tank on your model.

You may use your sewage system for several days before you will need to use a disposal facility. To extend the length of time between dumpings, water conservation should be practiced.

### To Drain Holding Tank

To drain holding tank at sewage disposal station:

1. Make sure the holding tank drain valve is closed (handle pushed in).
2. Remove the drain cap.
3. Attach sewer hose (stored in square rear bumper) to drain.
4. Insert opposite end of hose in sanitary station receptacle.
5. Open the drain valve.
6. After sewage has drained out, run water in the sinks and flush the toilet two or three times to flush the system.
7. After all waste has drained out of the unit, close the valve, remove the sewer hose and replace the drain cap.
8. Rinse out the sewer hose. Replace hose inside square rear bumper. Replace bumper cap.

If you are traveling on, place a small amount of clean water in your holding tank, along with a recommended amount of commercial cleaner such as Pink Magic (available at your dealers), so that it will slosh around and clean the tank while you are driving.

### Toilet

The marine toilet is a fresh water, permanently in-

stalled sanitation system. It uses the mini-rinse flushing principle, which utilizes high velocity water injection, micrometrically measured to produce a "swirl effect" in the bowl. A self-cleaning, odor-tight, gas-tight, teflon seal closes off the holding tank from the toilet when the unit is not in use. Since each flush uses fresh water, no mandatory chemical additives are necessary.

If your unit is equipped with an optional electric toilet, it operates on the principle of recirculating water and a chemical charge through a self-cleaning filter. With this method you are not adding water to the holding tank with each flush.

To flush, simply press the black button. When the color of the chemical water solution changes from blue to greenish, empty the unit and recharge with fresh water and additional chemical. Refer to the toilet manufacturer's operating manual for operation instructions.

### Tips

Care should be exercised to insure long life and maintenance-free operation of your drainage system. The following guidelines are recommended:

1. Provide waste cans for facial tissues. They can clog drains.
2. Use ashtrays for your cigarettes as nicotine reduces the action of cleansers.
3. Check after flushing to make sure that paper has not jammed in the valve. If this happens, the paper holds the valve open and water may trickle through continuously, wasting both water and holding tank space.
4. Do not use detergents or bleaches. They may attack certain parts of the system. You should only use commercial cleaners recommended by your Coachmen dealer.
5. Do not use automotive antifreeze, alcohol, ammonia or acetones in your holding tank. If you are storing your travel trailer for the winter, read section in manual on winterizing.

### Vents

The sewage system of your trailer is provided with vents. These vents carry out undesirable odors which accompany drainage and sewage and permit a continuous flow through your system. These vents should be checked to make sure they are open at all time.

## CHAPTER 7

### ELECTRICAL SYSTEM

The electrical system in your Coachmen travel trailer is designed with an up-to-date 2-voltage electrical

system to provide you with the convenience of electricity wherever you may be located. The versatility of this system allows you to operate lights and other electrical equipment in your travel trailer either self-sustained from your 12-volt battery or connected to a 120-volt AC park power source. The following methods of operation can be used, depending on the options incorporated in your trailer.

1. Operate from the towing vehicle battery power.
2. Operate from the battery installed on your trailer.
3. Operate from 120-volt park power source and/or your battery.
4. Operate from 120-volt park power source.

### 12-Volt System—Towing Vehicle

The 12-volt system is wired into the wiring system of the towing vehicle by means of connecting pigtail. The wiring code for the 6 or 7-prong plug is as follows:

Red .....	Left Turn Signal
Brown .....	Right Turn Signal
Green .....	Tail and Clearance Lights
Black .....	12-volt Hot Wire
White .....	Ground
Blue .....	Electric Brake Hot
Yellow .....	Back-up Light (optional)

When connecting the travel trailer to your towing vehicle, be sure there is enough slack in the wiring to allow turning, but not so much that it will drag on the ground or catch passing objects.

You can recharge the battery and obtain additional use by starting the towing vehicle and allowing it to idle fast for about 30 minutes. A 10-mile drive will achieve the same thing. **(Care should be exercised to insure that you do not wear down the battery in the towing vehicle so low that you are unable to start the towing vehicle's engine.)**

### Optional Battery Power Pack

If you have an optional battery power pack, a 12-volt storage battery, disconnect the connector plug from the towing vehicle and use this battery pack for your 12-volt system. The negative post of the battery is grounded to the trailer frame through a 20-amp fuse. The positive terminal is connected to the black wire from the connector.

If you want to charge the trailer battery while traveling, a separate No. 8 stranded wire must be run between the vehicle alternator and the trailer battery.

If you have an optional battery charger, it may be left permanently connected to the battery so that to charge the battery, plug the charger power cord into the 120-volt receptacle. An automatic shut-off prevents overcharging.

When operating from the 12-volt battery only, you cannot use your 120-volt convenience outlets or 120-volt lights (Cadets).



The refrigerator should be operated on propane. Your optional air conditioner operates only on 120 volts. At least one 12-volt utility outlet is provided in your unit.

**IMPORTANT:** When operating from your 12-volt storage battery, you should minimize current usage to prolong the life of your battery. An indication of a low battery condition is the gradual dimming of the 12-volt lights. Be sure to check the water level in battery often and fill if necessary. Make sure that the water level is above the plates in each cell.

### Break-Away Switch

The break-away switch is mounted on the trailer hitch so that if the car were to separate from the trailer on the road, the pin would be pulled and would cause the switch contacts to close and activate your trailer brakes. Do not use this breakaway switch for parking your trailer. If for any reason a separate trailer battery is not installed on your unit, a separate 12-volt dry cell should be used as a source of power for the break-away switch. Be certain the dry cell is functional.

### 120-Volt Operation

Your trailer is provided with 25 feet of 30-amp 3-wire power cord. This cord is for connecting to a 120-volt electric park power source. Do not connect to higher voltage. The 120-volt system is grounded to the trailer frame. To complete this ground circuit, you must plug into a grounded power supply.

It is the trailer park operator's responsibility to provide a grounded power source. However, if you have any reason to doubt the effectiveness of the grounding provision at the campsite, you should insure proper grounding with a grounding stake. You can obtain a ground by running a heavy copper wire (No. 8) from the frame of the unit to a metal stake driven into the ground. Make sure connections are tight.

The other end of the power cord connects to the distribution panel in the trailer. Circuits are provided with a 20-amp circuit breaker (15 amps for Canadian

units) and are wired to 120-volt receptacles (at range, dinette, vanity/night stand, in bath and in the refrigerator compartment) and to 120-volt lights (Cadets).

Should your electrical power go off, check the circuit breaker and reset. If the circuit breaker again releases, you should then check for a short. Your trailer is equipped with a weatherproof outside receptacle (optional on Cadets) for your convenience.

### Power Converter (Optional in Cadets)

When your trailer is equipped with a power converter, it will provide 12-volt DC power to operate all 12-volt lights and 12-volt DC motors in your trailer when connected to an external 120-volt power source. A deluxe converter is available as an option with an automatic charger.

The power converter is a solid-state device which converts 120 volts AC to 12 volts DC. If the converter is operated beyond its maximum continuous load limit, a circuit breaker built into the converter will automatically "break" the power to the 12-volt lights and motors. After a few seconds, this circuit breaker will automatically reset itself and the 12-volt system will resume operation. However, the circuit breaker will shortly "break" again if you are overloading the circuit.

Fuses are installed on the converter for individual lines to lights and motors. If a fuse blows, correct the overload or short condition and replace fuse— **never put in a fuse larger than indicated.**

### Exterior Lights

The clearance lights, tail lights, brake lights and turn signals all operate automatically when you use your towing vehicle lights.

If they fail, first check the fuses on the towing vehicle. If these are OK, you may have a poor ground connection in the towing vehicle or a defective connector between the trailer and towing vehicle.

### RUNNING LIGHTS OUTSIDE

<u>UNIT</u>	<u>LOCATION</u>	<u>TYPE</u>	<u>USE</u>	<u>ELECTRICAL SPECIFICATIONS</u>
Tail & Stop & Signal	Rear of Trailer	1157		12-Volt
Side Marker, Clearance	Front, Rear/Sides	57		12-Volt
Compartment, Trunk	Storage Area	1141	Opt.	12-Volt
Backup	Rear of Trailer	1156	Opt.	12-Volt
120 Volt 60 cycle AC				
Converter	Various	Phillips	Opt.	Input 120 VAC Output 12 VDC
Refrigerator	Various		Std.	120 VAC-12VDC plus gas
Air Conditioner	Roof		Opt.	120 VAC 12 and 22 amps only

<u>UNIT</u>	<u>LOCATION</u>	<u>TYPE</u>	<u>USE</u>	<u>ELECTRICAL SPECIFICATIONS</u>
Battery	Battery Box	6½x9¾x10¼	Opt.	12-Volt 65-amp hr./85 Royals
Lights	Various Inside	25 Watt	Std.	12-Volt 2.5 amp
Lights	Various Inside	1141	Opt.	12-Volt 1.4 amps.
Lights	Bath	1141	Std.	12-Volt 1.4 amps.
Lights	Porch Outside	1141	Std.	12-Volt 1.4 amps.
Range Fan	Over Stove	Vent-Line C1060H	Std.	12-Volt 4.0 amp only
Roof Vent Fan	Roof	Vent-Line V2026	Opt.	12-Volt 4.0 amp or as ordered
Refrigerator	Various	Astral	Std.	120 VAC-12VDC—plus gas
Air Compressor	Various	Miller 4000	Opt.	12-Volt 13 amp only
Water Pump	Various	PAR	Opt.	12-Volt 6.2 amp only
Furnace Fan	Various	Duo-Therm	Opt. 18½, 19 & 20'	12-Volt 0.6 amp only
Furnace Blower	Various	Duo-Therm or Suburban	Std. 21' & over	12-Volt 2.4 or 4.2 amp only
Monomatic Toilet	Bath		Opt.	12-Volt 9 amp only
Break Away Switch	On Hitch		Opt.	12-Volt

### ELECTRICAL SYSTEM TROUBLE SHOOTING

<u>PROBLEM</u>	<u>POSSIBLE CAUSE</u>	<u>SOLUTION</u>
No 12-Volt Power	Connector and/or battery not connected	Make necessary corrections—check battery terminals for corrosion.
	Blown Fuse	Replace fuse
	Battery shorted	Replace battery
No 120-Volt Power	Switch off at park box	Push handle up
	Circuit breaker open	Reset circuit breaker
Dim lights or sluggish fan motor	Discharged battery	Charge battery
	25 or 50 cycle power	Use 60 cycle power
Blown fuse/circuit breaker	Overload circuit	Turn off switches to reduce load & replace fuse/reset breaker
	Electrical short	Disconnect appliances from circuit. Replace fuse/reset breaker, then plug in one at a time to locate defective one; if none, check for defective wiring.
	Battery shorted	Replace battery — replace fuse/reset breaker
	Battery terminals not properly connected	Make proper connections and replace fuse/reset breaker
	Incorrect input line voltage such as 240-Volts or 95-Volts.	Connect to 120-Volt 60 cycle power.
Converter automatic circuit breaker clicks on & off.	Shorted battery	Replace battery
	Over-loaded circuit	Turn off switches to reduce load.

### CIRCUITS

No. 1	General Circuit - 20-amp - lighting, appliances and converter
No. 2	Air Conditioner Circuit - 15-amp

### CANADIAN CODE CIRCUITS

No. 1 - Appliance	15-amp
No. 2 - Air Conditioner	15-amp
No. 3 - Converter	15-amp
No. 4 - General - Lighting	15-amp

## CHAPTER 8

### LPG SYSTEM

The gas system provides for cooking your meals, heating your water, warming your trailer in cold weather and also operates the gas/electric refrigerator when you set the refrigerator on gas. LPG is convenient, safe in operation and in most cases, readily available. The gas is carried with you and can be used anywhere since no external hookup is required. Do **not** connect your trailer to natural gas. Your appliances are designed to work on LPG.

LP-GAS (Liquified petroleum gas) is a true gas compressed into liquid form for easy transportation and storage. It is also known as butane, propane or bottled gas. It is safe, economical and because of its portability, provides modern living conveniences no matter where you travel.

The LP gas system in your Coachmen travel trailer consists of gas containers, shut-off valves, a pressure regulator, water heater, furnace, gas/electric refrigerator and stove/oven.

Butane and propane are the two fuels used. Butane boils (makes vapor gas) at temperatures above 30 degrees F. Propane boils (makes dry gas) at temperatures above 44 degrees F below zero.

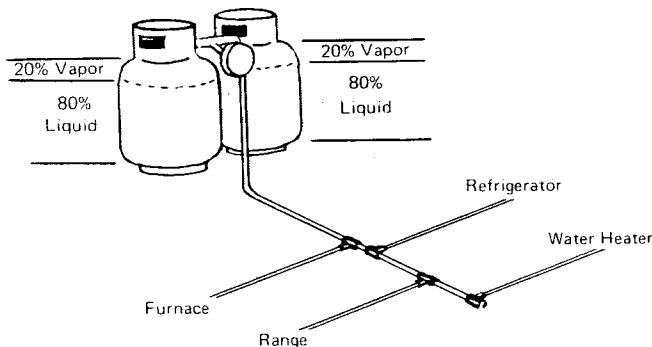

#### LP Gas Tanks Should Not Be Over-Filled

The LP gas tanks in your Coachmen travel trailer are designed with a substantial safety factor. This means they are tested to withstand pressures well in excess of what they normally would be subjected to in ordinary usage. Every LP gas tank has a safety feature built into it because they are designed to be filled only to 80% of capacity.

The other 20% volume provides vapor space which allow "expansion" room and vapor withdrawal through a service valve as the outside temperature rises. Fill the tank only to 80% full.

#### HOW MUCH LP GAS DO I HAVE IN MY TANK?

The only accurate way to determine how much LP gas you have in a tank is to weigh the tank, then subtract the tare weight of the tank (which is stamped on the tank name plate) to arrive at the correct weight. A 20-pound tank is filled to roughly 80% when it weighs 20 pounds plus the tare weight. The same formula applies to a 30-pound tank.

To remove a gas tank, close the tank valve and disconnect the tubing nut, using a tight-fitting wrench. This nut has a left-hand thread. Always turn it clockwise to loosen and counter-clockwise to tighten. Loosen the bar handle located between the two tanks which holds the tanks in place. Remove the tank.

To re-install a tank, set the bottle on the mounting plate, connect the gas line, tubing nut, turn left-hand thread out and tighten with wrench. Tighten the bar handle to hold the tank in place.

**Never** open the valve on both tanks at the same time, as you will drain from both tanks unless you have an automatic changeover valve. **Always** close the gas valve on the tanks while traveling. (This is the law in many states.)

In selecting the proper fuel, temperature and climate will probably limit your choice. In sub-tropical areas, hot desert or any warm locale, butane is the best because it has a higher boiling point. That is, it converts from a liquid to a gas at any temperature over 32 degrees F. Below that point, butane will not function. In cold climates, propane would be the logical choice since its boiling point is way down to 44 degrees below zero. It is unlikely that many trailer owners will experience such low temperatures. In actual practice, many companies today are offering a mixture of butane and propane. The boiling point would be somewhere between 44 degrees below zero and 32 degrees above zero F, a wide enough latitude to handle most every season. Local conditions will determine the selection of the LPG the supplier offers for your tanks.

Butane and propane as a gas are both heavier than air. That simply means that when released into the atmosphere, butane and propane will flow to a low point. Actually, both gases diffuse with air quite readily.

Butane and propane are tasteless and odorless. That peculiar odor you often smell is an artificially introduced chemical which allows the detection of escaping gas.

Your dealer should have checked out your gas system before delivery. If you have any doubts, have an authorized LP Gas serviceman check your system for leaks. The gas system was inspected prior to leaving the factory; however, we strongly recommend another check. We recommend that a gas system check be made each time the gas bottles are refilled or anytime you smell gas.

Never allow an open flame or smoking near trailer during gas checkout procedure. Never check for leaks with an open flame. To check the gas system, shut off all

knobs and controls on water heater, gas range, oven, refrigerator and furnace/heater. Make sure the valve on the tank is open. Then check each and every fitting, valve, or connection with a soapy solution. Bubbles will appear where there is a gas leak. If a leak appears, tighten the fitting with a wrench until the bubbles stop. Be sure to check the fittings under the coach, as well as those inside the cabinets and adjacent to appliances. After you have made sure all fittings are tight, you are ready to use the system. Lighting of each appliance is discussed in the section dealing with appliances.

Anytime you light or relight a pilot, be sure the gas controlling device (knob, valve, etc.) has been in the "off" position for ten minutes or more. This should allow the dissipation of any gas which may have collected around the device.

### Do Not Use the Range or Oven for Heating the Trailer

Anytime appliances are lighted, you should have a window or vent open for ventilation. The water heater, furnace heater and gas/electric refrigerator have sealed combustion chambers vented to the outside.

Each 20-pound tank contains approximately five gallons of LP gas. There are 103,000 BTU per gallon. Multiplying this out, there are over one million BTU's in two full 20-pound tanks. If you take the BTU input on each appliance, you can calculate just how long a bottle will last, depending upon your own rate of use.

## CHAPTER 9

### APPLIANCES

For your complete comfort and enjoyment, your Coachmen travel trailer is equipped with appliances to make cooking, showering or just lounging a pleasure. Appliances include your American Gas Association (AGA) certified range and oven, gas/electric refrigerator, furnace/heater and hot water heater. They operate on LP gas (not natural gas), and your refrigerator also is equipped to operate on 120 VAC & 12VDC. The correct operation of each appliance is described in the following pages.

#### GAS RANGE/OVEN

The range has three or four top burners, depending upon your model. To light: Push in the knob and turn it to the left. Light the burner with a match. There is no pilot light for the burners on top of the stove. Be sure a vent is open while you are operating your range. The gas supplied to the oven is controlled by a shutoff valve which is located just under the top panel of the range. Raise up the top panel and you will find the shutoff valve at the right end of the manifold pipe. This valve need only be open when oven is in use. Should you turn off the gas supply, you will have to open this valve and light

the pilot light inside the oven.

The oven has a constant burning pilot which burns all the time the gas supply is on to the oven. When the thermostat (oven knob) is turned on, a second pilot ignites from the constant pilot. This pilot heats an element which in turn opens the safety to allow gas to flow to the oven burner.

#### Lighting Instructions for Oven:

1. Turn "on" gas to oven. (Shut off valve.)
2. Wait 60 seconds to insure that air has been purged from the line. Be sure oven knob is in "off" position.
3. The standby pilot adjusting screw located behind the oven thermostat is adjusted to full "on" from the factory. This is the correct position.
4. Light pilot with a match.

To use oven, turn oven knob to desired temperature setting. Before traveling be sure that the shut off valve is turned to the "off" position.

The pilots have been adjusted at the factory to operate under normal gas pressure; however, should you, by observing the flame, determine that adjustment is necessary, follow these instructions:

Remove the oven control knob by pulling on it to reveal the adjustment screws. With a screwdriver, adjust the standby pilot so flame is just visible past the first opening in shield. To adjust the heater pilot flame, turn knob to any position above the 140 degree mark on the dial and turn the pilot adjustment screw until a slight yellow tip appears on flame. Replace the oven thermostat control knob.

To remove the top of the range, grasp the top at the front burner opening and raise up. To replace, center top over burners and snap down. Enclosed in the oven when shipped, are clips to fasten top grates to top of the range. These would be used while the trailer is in transit to keep grates from falling off. They need not be used when the trailer is not in transit.

To remove the oven door, open the door. Insert a nail or rod into the hole of the arm connecting the door to the range. Grasp the arm close to the inside of the door and raise up both arms. This unhooks the arms from the door allowing the door to move forward and off. To replace the door, place the two hinge arms into the slots on front of the frame. Raise the door up to the arms and rehook by raising arms same as they were removed.

To remove the bottom of the oven, place one hand on the back of the bottom of the oven pushing down. Then place your other hand at the front of the bottom of the oven and pull forward. The bottom of the oven is now free from its hold-down clips. Lift it out.

Regular cleaning with a warm detergent solution and a soft cloth are all that is necessary to keep your range looking new and sparkling clean. This cleaning

should be done as soon as the range cools. Be sure to clean the filter in your range hood and the fan blades frequently. Grease spatters that are allowed to become hard will eventually bake on and become very difficult to remove. Frequent cleaning will prevent these spatters from baking on your range.

The windows on your range should be cleaned only after the range has cooled completely. If any gas ports on the burners are stopped up, clean with a toothpick—do not use a metal instrument as it may distort or enlarge the ports in the burner.

**CAUTION:** Never use steel wool to clean burner caps or bright chrome trim on your range, as it will dull the finish. Do not use a wet or damp cloth to clean the porcelain surface while it is still hot. The top is made of glass fused onto steel and may craze. While cleaning oven, be careful to avoid bending the tube clipped to the rear lining below the vent opening. This is the thermal sensing unit. Distortion of this tube could cause a variation between the oven temperature and the dial setting.

#### Troubles and Possible Solutions:

1. **Orange Colored Flames**—This is almost always caused by fine particles of dust that are drawn into the air opening and usually will burn out in a very short time.
2. **Yellow Tips on Burner Flames**—This is due to improper mixture of air and gas. See your oven/range operations manual for adjustment procedure.
3. **Oven Burner Does Not Ignite**—Check to see if the stand-by pilot flames are operating. If only the stand-by pilot is on, remove the oven control knob and turn the heater pilot adjustment screw counter-clockwise.

#### 3-WAY GAS/ELECTRIC REFRIGERATOR

We call this refrigerator 3-way because there are three ways you can use it.

1. In a trailer park with an exterior power source—use 120 volts.
2. Parked away from park service—use LP gas.
3. On the highway—use 12-volt operation from your battery.

The recommended routine when going on a trip is to plug in your trailer power cord at your home about six hours before leaving. Switch the refrigerator to 120V. This will mean that the refrigerator is cold before you start your journey. On the highway switch to low volt operation until you get to your destination. When you arrive, switch to LP gas or 120V.

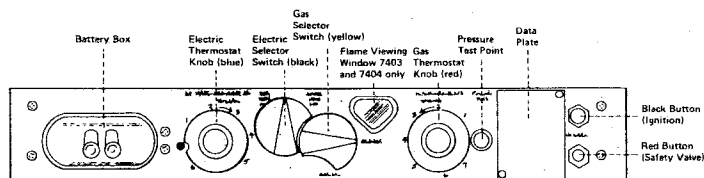

#### For Operation When Parked (120-Volt):

1. Turn YELLOW knob, gas selector switch to "gas off."
2. Turn BLACK knob, electric selector switch to "120V."
3. Turn BLUE knob, electric thermostat to "C."

#### For Operation When Parked (LP Gas):

1. Turn BLACK knob, electric switch to "off."
2. Turn YELLOW knob, gas selector switch to "gas on."
3. Turn RED knob, gas thermostat to "C."
4. Push RED (safety) button and BLACK (ignition) button at the same time.
5. Release BLACK button when you see the flame appear steadily through flame viewing window.
6. Continue to hold the RED button for 20 seconds.
7. Release RED button.

If the burner goes out, repeat procedures 4, 5, 6 and 7 above. **DO NOT use LP gas when in transit; use low volts instead.**

#### For Running on Highway (Low Volts):

1. Turn YELLOW knob, gas selector switch to "gas off."
  2. Turn BLACK knob, electric selector switch to "low volts on."
  3. Turn BLUE knob, electric thermostat to "C."
- Your refrigerator is now connected to your towing vehicle battery. When you arrive at your destination, switch over to LP gas or 120V.

#### Thermostat Controls:

Position "C" is the coldest setting.  
Position "D" is for defrost.

The numbers between are for you to judge for yourself how cold you need the refrigerator. The higher the number, the colder the refrigerator.

To make ice, fill ice trays with cold water and place them on the top shelf in the freezer. Turn the thermostat to position "C." Ice cubes take some time to form. It is advisable to keep the trays full and ready to use.

For proper storage of frozen food, adjust the thermostat control knob to position "5." If freezing occurs in the main food compartment, the thermostat setting should be turned to a lower number.

1. Adhere strictly to the recommendations for storage times suggested by the frozen food manufacturers for their products.

2. Do not store frozen food which has thawed and the carton has become limp and damp. Such food should be eaten within 24 hours and never refrozen.

3. Always place frozen food and ice cream in the freezer with the least possible delay after purchase. Buy frozen foods last on your shopping trips.

The cold drink shelf, located in the left-hand side of

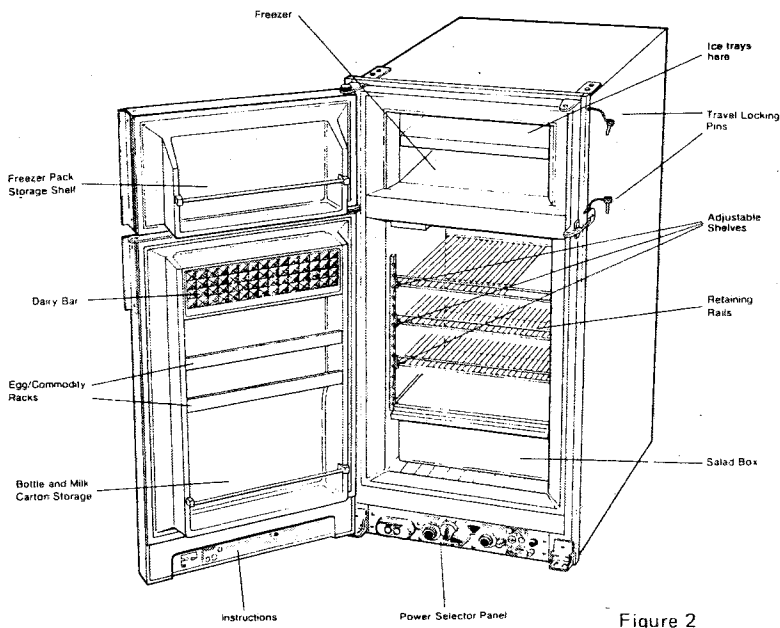

Figure 2

the freezer, is colder than the main food compartment. Use it to store cold drinks.

Defrosting is necessary because excessive build-up of frost on the cooling surfaces impairs the efficiency of the refrigerator. Humidity, frequency and the length of time the refrigerator door is opened, and improper storage of food affect the rate of frosting. Warm food should be allowed to cool before being placed in the refrigerator.

#### To Defrost:

1. Remove frozen food and ice cream, wrapping them in several thicknesses of newspaper.
2. Remove the ice trays. Turn the thermostat to position "D."
3. Empty the main food compartment and cold drink shelf. Leave the refrigerator door open. Make sure the drip tray is under the freezer.
4. When all the frost has melted, empty the drip tray, wash and dry the interior of the refrigerator and freezer with a clean cloth.
5. Replace the ice trays and food and set the thermostat to position "C" for a few hours. Then reset the thermostat to its normal position.

#### If Your Refrigerator Is Not Working Correctly, Check the Following:

1. Check to see that all starting instructions have been observed.
2. Check to see if excessive frost has built up on the plate, tubes or cooling fins. If it has, defrost the

refrigerator as noted.

3. Check to see that the thermostat tubes are firmly in place (see figure 3).

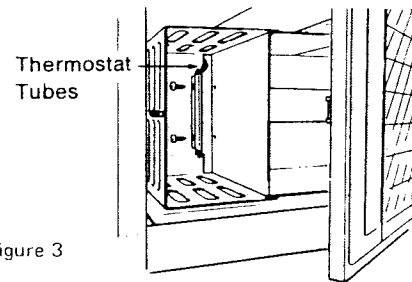

Figure 3

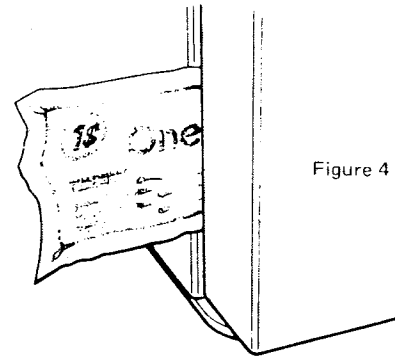

Figure 4

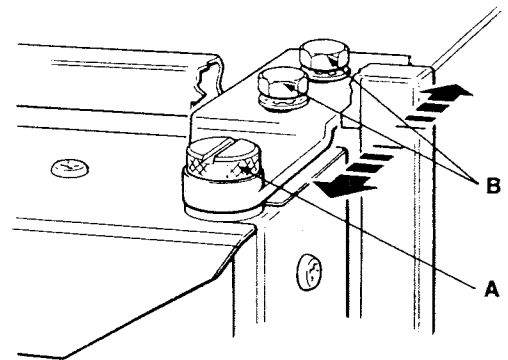
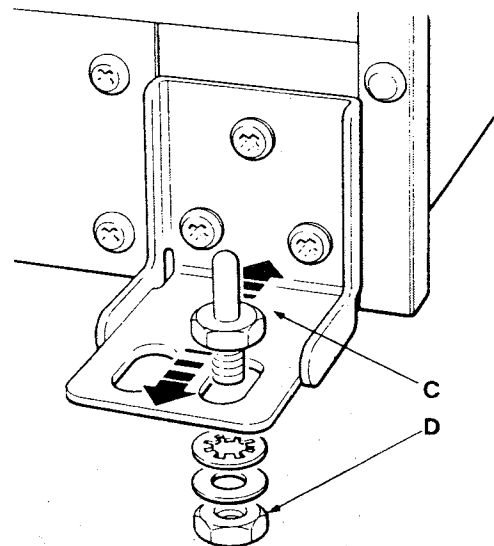

Figure 5



4. Check door seal all around. Put a dollar bill in the door as shown in Figure 4. When the door is closed, the bill should stay firmly held. If the bill slips, the door seal is not good. Smooth out the door sealing gasket. Look to see if the gasket on the door is twisted. Adjust the door with hinge pins as shown in Figure 5.

5. Examine the outside ventilator and roof outlet on your trailer (located above refrigerator). Make absolutely sure that they are clear and unblocked.

6. Make sure that hot air from adjacent heaters is well away from the refrigerator front.

7. If using gas, switch to electricity. If refrigerator then gets cold, something is likely to be wrong with the gas components. Go through the checks 9 and 10 (following).

8. Look through the flame viewing window shown in Figure 1 to see if there is a flame. If no flame is seen, go through starting instructions.

9. Check that there is sufficient gas in the supply tank. You can do this by turning on your stove and observing the flame.

10. Check that supply tank valve and the gas "on-off" valve in the supply line to the refrigerator are open.

11. Check that the two "D" cells are correctly fitted the right way around in the battery box, Figure 6.

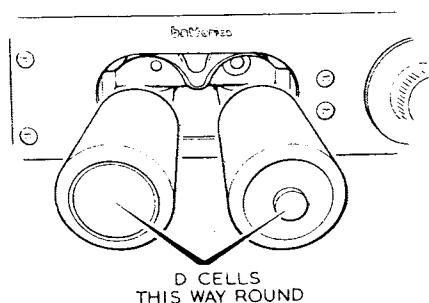

Figure 6

12. Check that the electrical contacts in the battery box cover are clean.

13. Check that you have good, fresh, clean "D" cells of the alkaline type. These "D" cells can be checked in your flashlight.

14. After all these checks, if you still cannot get a flame, it is possible to light your refrigerator from outside the trailer using a match. However, this means of lighting the burner requires two people—one to hold down the RED button and the other to apply the match. Open the ventilator on the outside wall of the trailer behind the refrigerator. Remove the screws holding the burner shield. With the RED safety valve button depressed, allowing gas to reach the burner, apply a lighted match to the burner to ignite the gas. Release the RED safety valve button after approximately 30 seconds. If the burner remains lighted, replace the burner shield and close and securely fasten the lower ventilator. If the burner is extinguished when the RED button is released, repeat the method. If the burner still

fails to ignite, report it to your dealer. Ignition with a match is only a temporary measure. See your dealer as soon as possible.

15. If you are using electricity (120-volts), check that the electricity supply is connected and that the circuit breaker and wiring are in order.

16. If using low volts, check that the battery supply is connected and that the fuses, circuit breaker and wiring are satisfactory.

17. Insure that the battery has sufficient power to operate the refrigerator.

**NOTE: DO NOT attempt to loosen the gas connections on your refrigerator. Leave these tasks for your authorized dealer. If you feel that your gas pressure is not correct, visit your nearest authorized Coachmen dealer for service. DO NOT attempt any adjustment yourself. Whether or not your refrigerator gives good service after these checks, it is always advisable to have your dealer check any adjustments you have made.**

If your refrigerator still fails to operate on gas, 120-volts or 12-volt electricity, be sure to turn off the gas supply and the electric supply at the switch. Notify your dealer, giving him the model and serial numbers of your unit, so that he can properly service your refrigerator.

## WALL HEATER

### (FOR TRAILERS 15 TO 22 FEET LONG)

This heater is for the smaller trailers. It has 16,000 BTU input and a wall-mounted thermostat. Following are the lighting instructions:

1. Adjust thermostat dial to "off" position.
2. Be sure all gas valves in supply line are open.
3. Turn gas control dial to "off," open lighter door and wait 10 minutes.
4. Rotate dial to "pilot." Depress dial while you are lighting the pilot burner. This is easily accomplished by using a wooden type kitchen match.
5. Keep dial depressed for one minute after pilot starts burning and rotate dial to "on" position.
6. If pilot goes out, repeat steps 3 through 5.
7. Close lighter door after lighting heater.
8. Adjust thermostat dial to desired temperature.
9. If pilot goes out, turn gas off, open lighter door and wait 10 minutes before repeating steps 4, 5, 6 and 7. If pilot needs adjusting, remove pilot adjusting cap and adjust screw so flame completely envelops the end (approximately 3/8") of thermocouple.
10. For complete turn off of your heater, push in on dial and rotate dial to "off" position.
11. If heater is equipped with a blower, an automatic switch will turn on when needed. Blower switch may be placed in "off" position when blower operation is not desired.
12. An air adjustment screw is provided on your

heater. See operations manual for adjustment.

### **FURNACE (FOR TRAILER 21' AND OVER)**

The furnace in your trailer is ducted to give you heat throughout your unit. It is also equipped with a wall-mounted thermostat. The furnace uses outside air for combustion. The burned gas is exhausted to the outside. When you require heat, light your furnace and set the thermostat to the temperature you desire. The furnace will operate automatically giving you heat throughout your unit. Below is an explanation of the operation of your furnace.

When the thermostat reaches a pre-set temperature a valve is turned on allowing gas to the main burner. The pilot light then ignites the main burner giving you heat. When the desired temperature is reached, the main burner turns off. The blower will continue to run for a short period of time and will then shut off automatically. The furnace will complete this cycle every time the temperature drops below the setting you have selected on the thermostat.

#### **The Blower Serves Two Functions:**

1. Brings outside air into the combustion chamber and forces the combustion products out the exhaust tube to the outside of your trailer.
2. Circulates the room air across the heat chamber and out into the trailer area.

Although only one motor is used to drive the two blowers, the combustion air blower is sealed so as to allow no passage of air between the combustion chamber and the interior blower fan. The blower motor works either on 120-VAC or 12V.

Sometimes when the furnace is running, you may hear a slight snap noise from inside the furnace. This snap is caused by the fan switch as it changes position and is a normal part of the unit's operation.

#### **Lighting Your Furnace Is Very Simple; Follow the Instructions Listed Below:**

1. Turn the manual valve located next to your furnace to the "off" position and wait 5 minutes. Set your wall thermostat at its lowest setting. Open the gas line manual valve to its full open position. Correct operation depends upon this valve being fully open. Never attempt to operate the furnace with valve partially closed.
2. Remove the lighter hole cover.

**NOTE: If you have an ignitor button, pump it in and out three or four times to light the pilot, instead of using a match.**

3. Press reset button and hold. Insert a burning match through opening so that flame is near the pilot. On the initial lighting, the pilot may not light

immediately due to air in the gas line. If this is the case, it may be necessary to hold the reset button in for approximately 30 seconds, or until the pilot light will light and continue to burn when the reset button is released.

4. Replace the lighter hole cover.
5. Close the metal furnace door.
6. Set your wall thermostat to the desired temperature.

To adjust the pilot or the main burner, remove the front cover of the furnace by removing the two screws which are located at each side of the cover. The pilot flame on your furnace should be just high enough to envelop the thermocouple. If it is too high or too low, turn the adjustment screw on the pilot regulator located in the brass fitting in the pilot light gas line.

To adjust the air to the main burner, it is necessary to remove the small sheet metal cover located below and to the right of the lighter opening. Behind this cover there is a slotted screw head. With a screwdriver turn this screw head counter-clockwise for less air and clockwise for more air to the main burner. A symptom of too much air will be a howling or screeching noise when burner is fully ignited (reduce the air flow to correct this situation). A symptom of too little air to the main burner would be the depositing of soot on the exterior vent of your furnace, along with a distinct yellow floating flame in the furnace (increase the air supply to the main burner to correct this situation). A slight trace of orange should remain at the tip of the burner flame; this is a sign of correct adjustment.

If for any reason the main burner of your furnace has been allowed to operate with a high yellow flame, a soot formation is sometimes deposited inside the combustion chamber. This carbon deposit may require cleaning. To clean the combustion chamber, shut off furnace and allow time to cool. Insert the end of your vacuum cleaner hose in the access hole on the front of the radiation chamber of your furnace. The suction of your vacuum should clean out any carbon deposit in the combustion chamber.

The fan motor requires no oiling since it is oiled and sealed at the factory.

#### **Trouble Shooting the Heating System:**

##### **No Heat—**

1. Thermostat off. Check to be sure thermostat is set high enough to call for heat. The wire to the thermostat could be off the terminal under the cover on the wall thermostat.
2. Gas supply. Be sure manual gas valve is in the open position (parallel to gas line). Be sure that there is gas in the gas bottles.
3. Pilot. Be sure the pilot is lit.
4. Electrical connections and power. Be sure your battery is charged. (The motor in your furnace must run at full speed for the furnace to operate properly.) Check



your circuit breaker and fuses to be sure current is being supplied to your furnace.

#### **Pilot Fails to Light—**

1. Gas supply. Check for gas, as in 2 above.
2. Igniter fails to light. Check position of tip. Align the igniter tip with the flow of gas to the pilot through the igniter hole. A match can be used to light the pilot if necessary.

3. Adjustment of pilot. You may need to adjust your pilot to insure proper operation of the furnace.

If the above techniques fail to produce heat, check with an authorized dealer.

#### **WATER HEATER**

Your water heater is a safe, fast-return and convenient appliance to supply your hot water needs. Access to the water heater is available by removing the outside exterior panel cover.

#### **Operation Instructions:**

1. Turn main gas knob to the "off" position. Wait 10 minutes.

2. Turn lighting/control dial to pilot counter-clockwise against the spring loaded stop when you are lighting the pilot with a match. Continue to hold against this stop for 30 to 60 seconds until pilot remains lighted when you release the dial.

3. Turn control dial clockwise to "on" for automatic control.

4. Set selection lever for desired temperature setting for your water.

5. To shut off the water heater, turn the gas knob to the "off" position.

To adjust the pilot on your water heater, remove the pilot adjustment cap which is located at the lower right side on the front of the control. Located behind this cap is an adjustment screw. When you rotate this screw clockwise, you will reduce the size of the pilot flame. When you rotate the screw counter-clockwise, you will increase the height of the pilot flame. **CAUTION: Always replace the pilot adjustment cap to prevent gas leakage. The pilot should burn with a small yellow tip when it is properly adjusted.**

#### **Burner Adjustment:**

The air shutter on your water heater can be regulated to increase or decrease the air supply to the burner. This is accomplished by loosening the air shutter screw and sliding the air shutter to create a larger or smaller opening as required. Proper air adjustment is attained when a yellow tip appears at the end of the main burner flame. Then slowly increase the air opening until the yellow tip disappears. Tighten the air shutter screw to maintain this position.

**NOTE:** Travel in remote country areas, on dirt roads, or during periods of storage, may cause dirt and foreign

matter to accumulate inside the heater. Be sure to keep the front interior of your heater clean. Be sure that all air openings are free of any obstruction. Check prior to use. Clean with brush and soap and water.

1. To drain water from your hot water tank, open the drain valve, lift the lever on the relief valve (hold open) and allow to drain. Be sure all the faucets in your trailer are open to permit proper drainage of the hot water tank.

#### **If Your Hot Water Heater Is Not Working Properly, Check the Following:**

1. If pilot fails to light, check your gas supply.
2. Failure of gas to control temperature, check for obstruction at the rear fitting on manifold or possible mashed gas line.

3. Water dripping from bottom of the flue box is only condensation and will occur only while heating water in a cold tank.

4. If the heater smokes, open the air shutter. Take a one-foot length of clothes line rope, fray one end so that it is bushy and run it back and forth through the burner several times. This will clean obstructions in the burner. Spider webs cannot be blown out. (Spider webs are the greatest offenders.) Check the adjustment of the pilot light and the main burner for smoking. They may need adjustment.

## **CHAPTER 10**

### **THE 5TH WHEEL TRAILER**

This chapter is written specifically for owners of the Coachmen 5th wheel trailers.

With few exceptions, this entire manual applies to the systems, components and operation of the 5th wheel trailer. The differences are explained below:

#### **Towing Vehicle**

Pin weights range from 1200 to 1500 pounds for the three Coachmen 5th wheel trailers. As with any towing vehicle, heavy-duty tires and accessories are recommended. Check with your truck dealer to insure a proper match between your 5th wheel and your towing vehicle.

#### **Hookup**

The prime difference between the 5th wheel trailer and the conventional trailer is the method in which it is hooked to the towing vehicle. The 5th Wheel attached to the pick-up truck and the king pin on the trailer are coupled together and away you go. Follow the below-listed steps to hook up:

1. Make sure 5th wheel plate is properly lubricated with heavy-duty grease.

2. Slowly back up the pickup until the king pin on

trailer and the 5th wheel are properly aligned.

3. Pull the lever out on 5th wheel to open the locking clamps.

4. Slowly back the pickup until the king pin is in place and the clamps secured.

5. Close locking lever and insert safety pin.

6. Raise the jack pads  $\frac{1}{2}$  inch off the ground.

7. Ease forward slightly and watch for trailer movement to verify the proper hookup. While testing for proper hookup, at no time should the jack pads be more than  $\frac{1}{2}$  inch off the ground.

8. Retract the jacks.

9. Plug in the electrical connector between the trailer and the tow vehicle.

10. Turn on your lights; check to be sure that your brake and clearance lights operate. Ease the rig forward. Check to be sure your trailer brakes are operating by applying them with the separate brake control located on the dash of your vehicle.

To unhook the 5th wheel, simply reverse the steps above. As with any trailer, always block the wheels and make sure the jacks are on a flat surface.

#### **IMPORTANT:**

The 5th wheel plate and the locking assembly should be lubricated thoroughly due to the fact that the Prior Assembly is built to small tolerance and depends on lubrication for the locking mechanism to work properly. This will also let the pin box slide easier and the 5th wheel plate; and if a false hook-up is encountered, it will be easily detected due to a lack of friction between the metal surfaces.

## **CHAPTER 11**

### **OPTIONAL EQUIPMENT**

#### **Air Conditioner**

If your travel trailer is equipped with an air conditioner, you can enjoy total living comfort on those hot days and nights whenever you are connected to a 120V power source. The new adjustable, factory-installed air conditioner, in conjunction with the excellent insulation of the Coachmen trailer, provides the best in cooling comfort that technology has developed.

To cool the travel trailer with your air conditioner, follow these instructions:

1. Set the thermostat dial to the desired temperature on the air conditioner control panel.

2. Place the blower switch in the desired position (Hi-Cool or Low-Cool). The other two positions (Hi-Fan or Low-Fan) operate the fan only.

3. Adjust the air flow for the desired air distribution. This control (push-in and turn) diverts air all to the front, all to the rear, or divided equally in

between the front and rear.

4. Adjust the louvers on the air box for the desired air distribution.

After the temperature of the travel trailer is reduced to the desired temperature, you may wish to adjust the operation to Low-Cool or Low-Fan, or just alter the thermostat control until the temperature is as you desire.

To completely turn off the unit, place blower switch in the "off" position.

**NOTE:** When unit is turned on, the fan will start immediately. In approximately two minutes the compressor will start. After turn off, unit will not restart for approximately two minutes.

Your air conditioner is equipped with a permanent type filter which can be removed and washed in a solution of water and mild detergent. After you wash the filter, rinse it thoroughly and allow to dry before you replace it in the air conditioner. While your filter is out for cleaning, you should remove any lint from the air inlet duct so that the filter seats properly.

Should you require assistance in the operation and maintenance of the air conditioner, contact your local dealer for assistance.

#### **Television Antenna**

The optional factory-installed television antenna has a crank inside your unit. Turn the crank to raise or lower the antenna. Push up on the crank to turn the antenna to the desired direction. The crank for the antenna is located inside, just below the antenna.

#### **Tire Carrier**

The optional Kenco tire carrier is mounted on the rear bumper of your travel trailer. If the tire is in front of the trunk door, you need only to pull the ring behind the tire which allows the tire to fold down, thus giving you access to the trunk. An optional vinyl tire cover is also available to protect the spare tire from the sun.

#### **Power Roof Vent**

The optional power roof vent is equipped with an exhaust fan. To operate, open vent by turning crank clockwise. Then turn on the switch located on the fan. Reverse the procedure to turn off the fan and close the vent. Fan operates on 12V or 120 volts through the converter.

## **CHAPTER 12**

### **CONVENIENCE ITEMS**

The items described in this chapter are for your convenience.

### **Awning and Rock Shield**

Your front awning has a two-fold purpose. It protects your travel trailer window from rocks and debris when traveling. It also serves as an awning to reduce the glare of the sun inside your unit. To use the awning, release the pins on each side and extend the awning slide to the angle you wish. Lock in place by tightening the wing nuts on each side. To secure for traveling, loosen the wing nuts, close the awning and secure each side. Do not travel with the awning raised.

### **Fold-Away Step**

Your travel trailer main door step is located below the main door. Lift slightly and slide the step out, lowering it so that it locks into place. To return step, simply lift and push in until it locks into place.

### **Assist Handle**

Your travel trailer is equipped with an assist handle next to the main door. The assist handle should be used to steady yourself as you enter the unit.

### **Main Door**

The main door in the deluxe series is a combination door and screen. Each may be opened as a separate unit.

The main doors are provided with a security lock which may be locked on the inside by pushing down on the handle or on the outside with the key. You cannot inadvertently lock yourself out, since you must use the key to lock the door from the outside.

### **Storm Windows (Optional)**

Storm windows are available for your travel trailer. These storm windows clip on to the inside of the window.

### **Roof Vent**

Your travel trailer is equipped with a roof vent assembly located in your living/dining area. This vent not only provides light for the interior, but it also may be opened for ventilation. Your travel trailer will be equipped with one to four roof vents, depending on the size and model of your unit.

### **Lighted Range Hood**

The canopy over your range is equipped with a light for range illumination. Models equipped with an oven are also equipped with an exhaust fan. It draws the cooking heat and fumes from your range and oven through a filter and discharges them outside of your trailer.

Be sure you have released the vent cover. A thumb latch is located on the right side of the filter. Certain Cadet models offer an optional sidewall vent. To operate, lift the bead chain to open the vent. The fan will automatically turn on. To turn off, simply pull the chain and re-hook.

### **Sliding and Folding Doors**

Sliding doors on some models operate on nylon roller and latch by means of a strap and snap. Folding doors on some models are held open by a strap and snap. A magnet in the handle holds the door closed. Both types of doors should be strapped open when traveling.

### **Drawers**

The drawers of your travel trailer are designed to resist accidental sliding. They are equipped with a positive catch. The drawers are equipped with center nylon roller guides. To remove the drawer, pull out and lower the front of the drawer. Lift up the back and pull drawer out.

### **Dining Tables**

**WALL BRACKET TYPE:** The dining table folds down to form a bed. Use the back cushion to cover the table to make a full-length mattress. To raise or lower the table, lift up the front of table slightly and squeeze the latch on the table leg, allowing you to fold the leg up under the table. Pull the table out from the wall and lower to the bed position. Reverse this process to raise the table.

**PEDESTAL TYPE:** The dinette table mounted on a pedestal leg also makes into a bed. Lift off the top of the table. Remove pedestal and store on the floor. Lower the table until it rests on the supporting rails. Place the back cushion on the table top to make a full mattress area. If your unit has a pull out gaucho/bed located behind the pedestal-type table, merely remove and store the table and pedestal and pull out the bed.

**EXTENSION TYPE:** The extension table is another type used in some travel trailer models. To use, simply lift up and fold the leg down. The locking mechanism on the support leg is released by squeezing the latch located on the upper part of the leg. To add the extensions to the table, release the ring under the table to unlatch and pull out. The extension leaves are stored behind the table.

**SLIDE-OUT TYPE:** The slide-out table found in some models is simply unlatched and pulled out. Lower the support leg.

### **Gaicho-To-Bed**

To convert the lounge into a bed, reach down and grasp the front rail of the seat assembly. Pull forward until fully extended. Slide the seat cushion to the edge of the rail and lay the rear cushion in place on the bed.

To convert the bed back to a gaucho, lift the cushion and place it on top of seat cushion. Reach over the cushions, lifting the sliding top part of the seat base, while at the same time pushing the front rail assembly back in place at the base of the gaucho. Adjust the cushion to its proper position.

### Cabinet/Bunk

These beds are hinged at the base of the cabinet and held in place by slide bolt latches located inside the cabinet. To open the bunk, simply pull the latches and lower the front of the cabinet down into place. Place the supporting bed boards on the cabinet front. This will give you a smooth bed base. Place the cushions on the base to make the mattress. To store, reverse this sequence. Be sure to secure the cabinet front latches.

### Hide-A-Bed

The optional hide-a-bed is supported by two brackets mounted on the side of the trailer. To raise or lower the bed simply push up on the rear section of the bed. This disconnects the clamps and allows the bracket to rotate downward. Lower the bed onto the bracket. To return the bed to storage, reverse the above procedures.

### Termination Guards

Termination guards are installed on rear bath models. They protect the plumbing at the back of your trailer while you are traveling over a sharp rise in the road, such as a driveway or railroad crossing.

## CHAPTER 13

### CARING FOR YOUR COACH

#### Exterior

The exterior of your coach is prefinished baked enamel and aluminum. No strong abrasives should be used to clean your unit. Frequent washing with a mild detergent is recommended. It is best to wash it in the shade to minimize water spotting. Touch up any nicks or scratches as they develop.

A good automotive cleaner wax should be used occasionally to remove road tar, insects and other stains.

#### Interior

Interiors of Coachmen trailers are primarily natural wood and vinyl. Use the same cleaning methods as you would in your home.

#### Cleaning Cushions and Draperies

The following methods are recommended for cleaning cushions and draperies:

**CUSHIONS**—Use a light detergent and clean with a sponge application. You may also use a commercially available upholstery-type foam cleaner. **Do not remove**

the cover from the cushion.

**DRAPERIES**—Use a mild detergent and totally immerse the draperies in lukewarm water. Hand wash. **Do not use dry-cleaning methods as it removes the fire-retardation from the material.**

## CHAPTER 14

### TRAILER STORAGE AND WINTERIZING

There is danger of damage from freezing if water remains in the water lines, drain systems (including traps), water pumps, holding tanks and water heater in your travel trailer. To winterize your trailer, follow this procedure:

1. Dispose of the water and sewage in your holding tank at a sanitary dumping station. Rinse the holding tank and drain lines well.
2. Open all faucets, including shower head (if so equipped).
3. Open drain valves on the:
  - a) Water tank  
Cross handle valve on Royal Coachmen.  
3/8" cap on other tanks.
  - b) Hot water heater  
Relief valve and drain valve
4. Open and flush toilet flushing valve.
5. Lower the front of the trailer as far as possible until water ceases to flow from the drain. Raise the front of the trailer as far as possible with trailer jack until water ceases to drain from this angle.
6. Close all drain valves and faucets.
7. Turn on the water pump.
8. Open each faucet one at a time to allow the remaining water in the lines to flow out.
9. Turn off the water pump.
10. Open all drain valves and faucets and leave them open.
11. Pour two cups of special non-toxic antifreeze each in the bath and kitchen sinks, toilet and tub or shower drains to prevent freezing in these traps.
12. Remove any other items from the inside of the trailer that might spoil or be damaged from freezing.
13. Open one window or roof vent slightly for ventilation in the unit.

**NOTE:** Since it is difficult to assure that all water has drained from any low spots in the water or drainage systems, we highly recommend performing steps 1 through 8 and then installing five gallons of special non-toxic antifreeze, such as "Winterize" (available from

your Coachmen dealer) in the water tank along with three gallons of water. Thereafter, follow this procedure:

- a) Turn on your demand water pump.
- b) Open each faucet, including the shower head, one at a time, until the mixture comes out of the fixture. Then close.
- c) Flush toilet.

Since the special antifreeze is non-toxic, you need only to drain the system and refill your tanks with fresh water and you are ready for the next trip. Run fresh water through your water system for a short time; the color of the antifreeze will disappear. Even if some slight color is left in the water, it is not harmful.

14. REMOVE THE BATTERY from the trailer, charge and store it in a warm place. The battery should be kept full of water and charged each month when your unit is not in use.

15. The trailer wheels should be run up on boards, the tire pressure should be reduced to 30 pounds, and most of the weight of your trailer should be supported by your four stabilizer jacks.

16. Turn off valves at the gas tanks.

17. Turn off all gas valves at each appliance—range/oven, refrigerator, hot water heater and furnace or heater. This will prevent any accidental leakage of LP gas into your unit, should someone turn on one of the valves at the gas bottles, or should you turn them on yourself next spring when you are preparing for a trip.

18. We recommend that you check your unit periodically during storage periods.

## CHAPTER 15

### MAINTENANCE

You will find your Coachmen trailer will provide trouble-free operation with a minimum of maintenance. You should check your wheel lugs for tightness every 50 miles for the first 200 miles. Torque right (85-90 ft. lbs.). Following is a guide to preventative maintenance:

#### After Every Trip

1. Inspect wheel lugs.
2. Check to see that both gas tank valves are off.
3. Drain and flush holding tank. Lubricate valve shaft with oil. **IMPORTANT: If a cleaning agent is used, it MUST be a preparation specifically for RV holding tanks.)**
4. Keep ends of equalizer hitch bars, hitch ball and hitch head at points of bar contacts clean. Lube hitch

ball with special hitch lubrication.

5. Check battery water level. Add as necessary.
6. Clean car and trailer electrical connectors.

#### Every 30 Days

1. Check battery water level and charge if necessary.
2. If your trailer is equipped with an optional air conditioner, the air filter should be washed in soapy water and then rinsed. The access panel can be removed by turning the two spring-loaded screws on the face of the panel.
3. Lubricate LPG bottle bracket assembly.
4. Wash range hood filter with soapy water and rinse.

#### Once Every Year (or 5,000 Miles) and After Prolonged Storage

1. Clean, repack and adjust wheel bearings.
2. Inspect and adjust brakes.
3. Clean battery cable connections at battery.

## CHAPTER 16

### MISCELLANEOUS GEAR

ITEM	WEIGHT IN POUNDS
Air Mattress	5
Aluminum Camp Cot	7
Aluminum Camp Cot w/Mattress	22
Army Cot	15
Auto Hand Vacuum	5
Ax	3-6
Battery	37-50
Battery Box (for boat)	3
Battery Charger	10
Bicycle	45
Binoculars	1½-5
Booster Air Shocks	14
Broom	2
Bucket/Wastebasket	2
Camera	3
Camera Outfit, Polaroid	7
Camp Folding Stool	1
Camp Folding Table	16
Camp Stove	18
Camper Fan	4
Camper Fold-away Steps	18-19
Camper Generator, 1100 Watt	70
Camper Stabilizer	8
Camper Sundeck & Ladder	19
Canopy	18
Canteen (2-quart)	1
Catalytic Heater	8
Chain Saw & Case	18
Charcoal	10
Charcoal Fluid Igniter	1

Chess/Checkers/Games	1
Clothes Line (50 foot)	1½
Clothes Pins (package)	¼
Compass	¼
Double Bass Drum Set (15 pc.) with cases	110
Electric Cable (100 feet)	10
Electric Fan 12"	10
Envelopes/Stamps	¼
Extension Rear Bumper	123
Extinguisher	5-17
Film, 4 rolls	1
First Aid Kit	3
Flag/Reflector Kit	7
Flare	¼
Flashlight	1
Floor Mats	11
Front Tire Carrier	7
Funnels (water, fuel)	½
Gas Lantern	6
Gas Stove (2 burner)	11
Gasoline Emergency Can (5 gal.)	11
Grease Gun and Grease	14-15
Ground Cloth	1
Guide Book	2
Hammer	1-2
Hand Saw	2-3
Hand Spotlight	2
Hatchet	2-3
Hiking Pack	3
Insect Fogger	7
Inverter, 12-volt	13
Iron	2½-4
Ironing Board (portable)	2
Jack	10-15
Lantern	6
Laundry Bag	1
Level	1
Maps (8)	1
Mess Kit (aluminum)	2
Mosquito Repellent (can)	1½
Movie Camera (8 mm)	4-8
Oil Paints	5-11
Easel	6
Padlock & Chain	1
Picnic Blanket	3
Playing Cards (2 decks)	½
Portable Toilet	20-30
Power Intercom	4
Propane (20-gal. bottle)	45
Propane Cylinders (disposable)	2
Radio, 2-way, 6-watt	7-8
Radio, portable	6-16
Refrigerator	100
Rope (100 ft., 5/8")	14
Roof Top Camper Air Conditioner	150
Sewer & Water Hook-up Kit	10
Sewing Machine	20-50
Shovel	4-5
Shovel (folding)	3
Spare Oil (10-qt can)	20
Stake Pocket Camper Hold-Downs (2)	9
Stereo Tape Player	10
Swing-Out Spare Tire Carrier	17
Tape Recorder	4-20
Tarp (10' x 12')	20

Television, Battery-Powered	10
Television, Portable B/W	20
Television, Portable Color	61-76
Tent, pup	12
Tent, large	70-80
Tire Chain Kit	3
Tire Gauge	½
Tire Iron	4
Tire Repair Kit	4 oz.
Thermos (1 qt. steel)	3½
Thermos (2 qt. plastic)	5
Tool Kit (65 piece mechanic)	15-21
Trailer, Cycle	225
Trailer, Tent	425-832
Trailer, Utility ¼ton	195
Travel Information	¼
Truck Washing Brush	3
Tune-up Kit	20
Two-Suiter Case	11
Typewriter	11-24
Umbrella	2
Vacuum	10-36
Water Heater	68
Water Purification Tablets	¼
Water/Tire Pump	6
Week-end Case	7
Writing Pad	¼

## CLOTHING

ITEM	WEIGHT IN POUNDS
Blouse, Shirt	1½
Coat, lined	4
Culotte	¾
Dress, Skirt	¾
Jacket, lined	2½
Jeans, Slacks	1-2
Pajamas	1
Raincoat	3-4
Shoes	1-3
Shorts	½-¾
Sunglasses	¼
Sweater	1
Swimsuit & Pullover	1½
Windbreaker	¾

## SPORT ITEMS

ITEM	WEIGHT IN POUNDS
Anchor (boats up to 14 ft.)	10
Semi-V Aluminum Boat	118-257
Boat Trailer	135-240
Canoe (aluminum)	65-75
Fishing Boat (fiberglass)	125
Fishing Kit with light tackle box	6
Fishing Motor (electric)	9-23
Jon Boats (10-16 ft. aluminum)	62-250
Outboard Motors up to 5½ hp	42-54
Remote Gas Tank (for boat)	5
Rubber Boat (8 persons)	85
Rubber Boat (2 persons)	15
Safety Vest (adult)	3

Safety Vest (child)	2
Tackle Box (large)	8
Oars	10
Cartridges (20)	2
Duck Decoys	9
Gun Case	2
Gun Cleaning Kit	3
Hunting Bow	4
Arrows (6)	1
Hunting Knife	8 oz.-1
Rifle (30.06)	7-12
Scope	1
Shotgun	9
Shotgun Shells (5)	1

Golf Bag	6-13
Golf Cart	16
Golf Irons (8)	11
Golf Set (child's)	11
Golf Woods (4)	7

Bat/Ball/Glove	6
Boots	3-5
Mini-Bike	84-170
Scuba Gear (with tank)	71
Skates	3-4
Snow Skis, Bindings, Boots & Poles	23-27
Water Skis	15-16
Tennis Racket with Cover, Press, Balls	3
Pool Table (8-ft)	306

#### BASIC KITCHEN ITEMS

ITEM	WEIGHT IN POUNDS
Abrasive Pads (package)	¼
Bags, Disposable (package)	1½
Basin/Rack (plastic)	2
Bottle Opener	¼
Can Opener (crank)	1
Coffee Pot	1-3
Cookbook	3
Cookware Set (8-piece aluminum)	11
Cookware Set (8-piece stainless steel)	15
Cooler (48-quart)	15
Cups, Disposable (40)	¾
Cutting Board	1½
Dinnerware (45-pc. plastic)	16
Dish Cloth (12" x 12")	1/8
Dish Towel	¼
Dishes (53-piece for 8)	40-60
Foil (cooking)	½
Fry Pan (skillet - 15")	13
Glasses (8 plastic)	1-3/4
Juice Container (plastic)	½
Knives (kitchen)	1¼
Matches (carton)	½
Mixer (portable)	3-5
Oven-Broiler	10-18
Plate Scraper	¼
Plates (40 disposable)	½
Pots & Pans (10 pieces)	14
Pot Holders	1/8
Soap/Detergent (box)	1
Spatula/Pancake Turner	½
Sponge	¼
Stirring Spoon	¼
Table Covering (plastic)	½
Tablewear (50 pc. stainless)	7

Thermos (1 gallon aluminum)	4
Toaster	1-9
Tongs	½
Toweling, Paper (per roll)	¾
Trash Caddy	2

#### BASIC OUTFIT FOOD AND BEVERAGE CHECKLIST

ITEM	WEIGHT IN POUNDS
Apple (large)	½
Bacon/Sausage	1
Baking Soda (box)	1
Banana (large)	½
Beverage (can)	1
Bread	1
Breakfast Cereal (box)	½
Butter/Margarine (carton)	1
Catsup (bottle)	1¼
Chili (can)	1¼
Cocoa	1¼
Coffee (1 lb.)	1
Cookies (package)	1
Cooking Oil (quart)	1½
Corned Beef Ham (can)	1¼
Crackers	1
Egg (fresh or hardboiled)	1/8
Flour/Pancake Mix (box)	1
Fruit (1 lb. can)	1¼
Fruit Juice (can)	1
Jelly/Jam	1¼
Macaroni/Spaghetti (can)	1¼
Milk (dried)	1¼
Milk (pint, carton)	1
Mustard (bottle)	1¼
Napkins (package)	¼
Olives (jar)	1
Orange (fresh, large)	½
Peanut Butter	1¼
Pickles (jar)	1
Pork & Beans (lb. can)	1¼
Potatoes/Rice	4
Poultry/Meat/Fish	4
Salad Dressing	1¼
Salt & Pepper (container)	½
Soup (can, condensed)	3/4
Spam (can)	1
Spices (assortment)	1
Stew (can)	1¼
Sugar (box)	1
Syrup	1
Tea (box of bags)	¼
Vegetables (lb. can)	1¼
Vegetables (fresh)	1¼
Water (per gallon)	8.4

#### BATHROOM SUPPLIES

ITEM	WEIGHT IN POUNDS
Bath Cap	¼

Bath Towel (22" x 24")	3/4
Chemicals (Toilet)	1
Cosmetic Case	5
Facial Tissue (box)	3/4
Hand Mirror	1
Hand Soap (bar)	1/4
Hand Towel (16" x 25")	1/2
Shampoo (tube)	1/4
Shaving Cream (can)	1
Shaving Kit	2
Sponge	1/4
Suntan Oil	1/4
Toilet Paper (roll)	1/2
Toothbrush Holder	1/4
Toothbrush & Toothpaste (tube)	5/8
Wash Cloth (12" x 12")	1/8

### BEDDING

ITEM	WEIGHT IN POUNDS
Blanket (twin)	2-5
Pillow	1-2
Pillowcase	1/2
Sheet, disposable	10 oz.
Sheet, twin	1-2
Sleeping Bag (cold weather)	13
Sleeping Bag (double)	16



## TRAVEL TRAILER INDEX

<u>Item</u>	<u>Page No.</u>	<u>Item</u>	<u>Page No.</u>
Accessories	24, 25, 26	Main Door	25
Air Conditioner	24	Maintenance	27
Appliances	18, 19, 20, 21, 22, 23	Optional Items	24, 25, 26
Appliance Serial Numbers	4	Oven	18
Assist Handle	25	Overnight Parking	11
Auxiliary Equipment	5	Parking	10
Backing	10	Passing	9, 10
Backing & Parking	10	Pigtail	14
Battery Power Pack	14	Power Converter	15
Blower, Furnace	21, 22, 23	Power Roof Vent	24
Brake-Away Switch	7, 15	Range	18
Brake Control	5	Recommended Items	7
Brakes	6	Refrigerator	19
Bulbs	15, 16	Resistor, Brake	6
Cabinet Bunk	26	Running Gear	6
Canadian Codes	16	Running Lights	15
Circuits	15, 16	Safety Chain	7
Cleaning Cushions & Draperies	26	Sanitizing Water System	11, 12
Component Parts	4	Serial Numbers	4
Converter	15	Shock Absorbers	5
Cushions	26	Side View Mirrors	5
Defrosting Refrigerator	20	Sliding Doors	25
Descending Grades	8	Springs, Heavy-Duty	5
Dining Tables	25	Stabilizing Jacks	7
Drain Hose	7	Storage	26
Drainage System	13	Storm Windows	25
Draining Water System	12	Stove	18
Draperies	26	Sway Control	5
Drawers	25	Termination Guards	26
Electrical Circuits	16	Tire Carrier	24
Electrical Components	16	Tires	7
Electrical Connector	14	Toilet	13
Electrical System	14	Tool Box	7
Electrical Trouble Shooting	16	Towing	8
Equalizing Hitch	5	Towing Vehicle	5
Extended Stay	11	Transmission Cooler	5
Exterior Lights	15	Travel Trailer Equipment	7
Fifth Wheel	23, 24	TV Antenna	24
Flasher	5	Wall Heater	23
Fold-Away Step	25	Warranty	2, 3
Foreword	1	Washing Exterior	26
Fuel Selection, LPG	17	Water Heater	23
Furnace	22	Water Hose	11, 12
Gas Range	18	Water Management	12
Heating System	21	Water System	11
Hide-a-Bed	26	Water System Trouble Shooting	12, 13
Hitch Height	5	Weight Distribution	8
Holding Tank	13	Wheel Blocks	7
Hooking Up	8	Winterizing	26
Inspections	27	120-Volt Operation	15
Jacks	7	12-Volt System	14
Level	7		
Leveling Ramp	7		
Lighted Range Hood	25		
Lighting Furnace	18		
Lights	15		
Loading	8		
L.P.G. System	17		

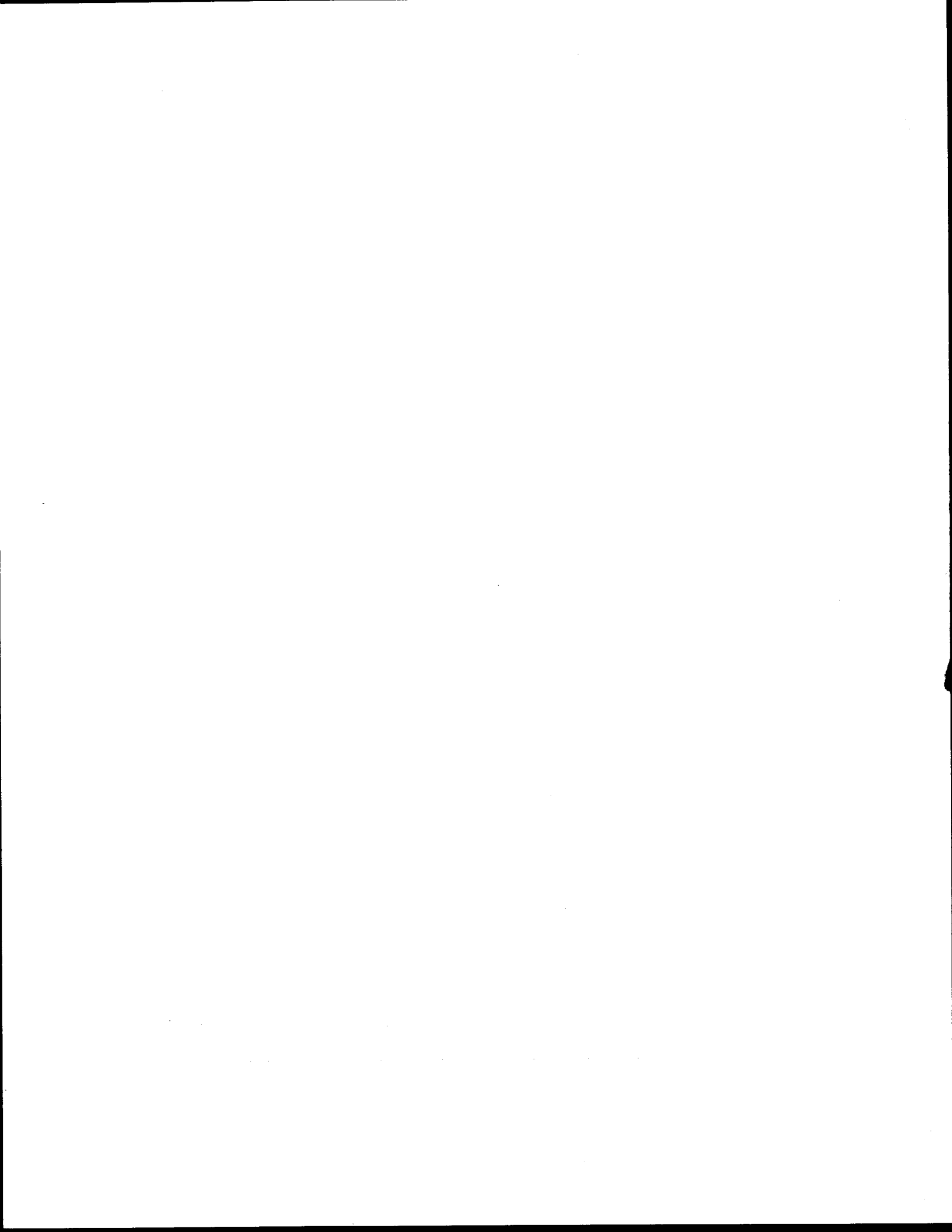

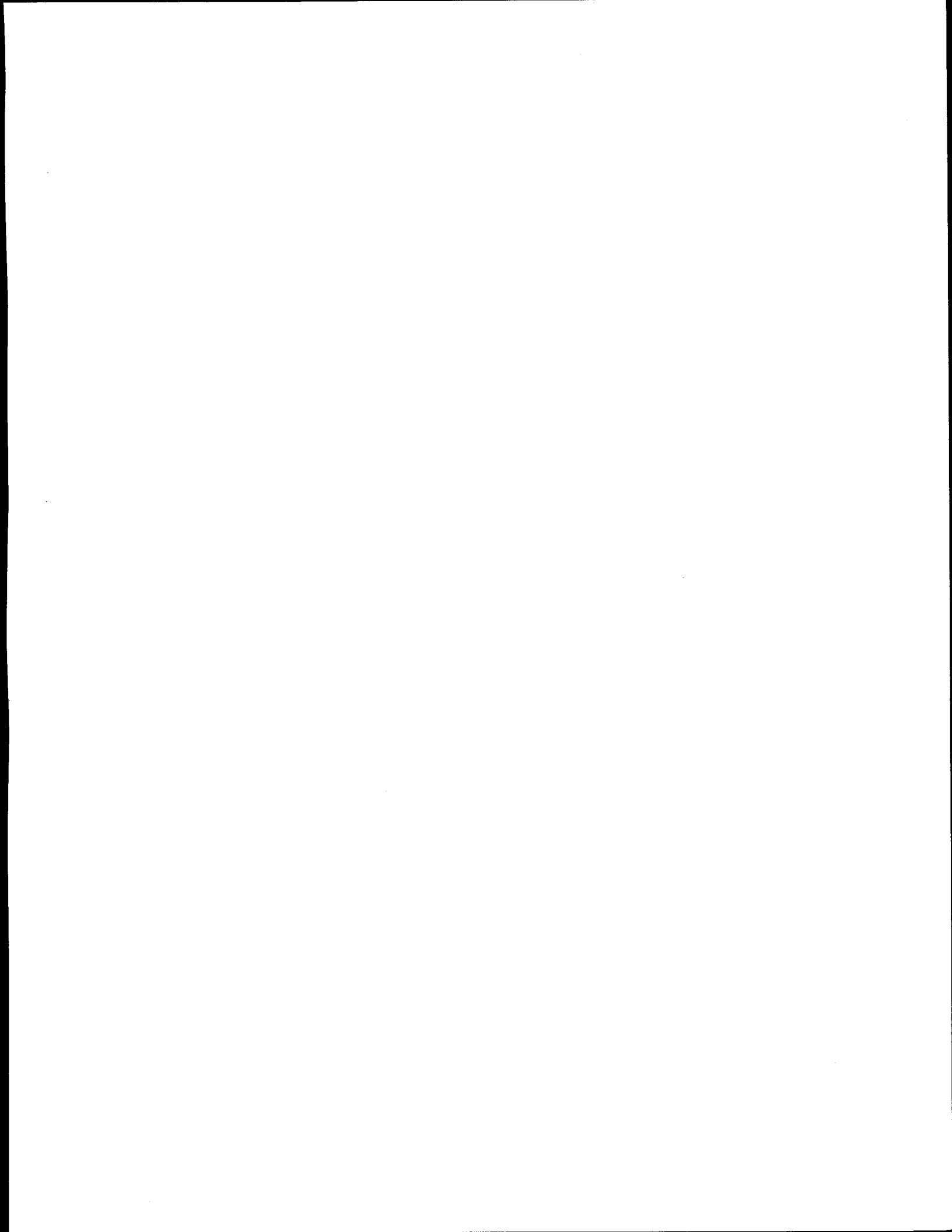

**TRAVEL TRAILER OWNER'S MANUAL**

**Serial No.** \_\_\_\_\_



COACHMEN DRIVE  
MIDDLEBURY, INDIANA 46540